

METHODS OF MOLDING RETENTION

BUICK "E" BODIES - 49000 SERIES
FIGURES 17-114 THROUGH 17-115

Key	Molding Name	Series or Styles	Screws	Spring (Self-Retained)	Snap-On Clips or Retainers On Panel	Snap-On Clips On Molding	Studs With Attaching Nuts	Engages With Other Moldings	Remove Hardware Or Trim
1	Windshield Reveal Upper	All			X				
2	Windshield Reveal Side	All			X			Windshield Reveal Upper	
3	Windshield Reveal Lower	All	X					Windshield Reveal Side	Cowl Air Intake Grille
4	Windshield Pillar Drip Molding Scalp	All		X					Windshield Pillar Weatherstrip and Weatherstrip Retainer
5	Roof Drip Molding Scalp	All		X				Windshield Pillar Drip Molding Scalp	
6	Front Door Window Belt Reveal	All	X			X			Rubber Bumper on Front Door Window Lower Stop
7	Rear Quarter Window Belt Reveal	All	X			X			Rear Quarter Window
8	Rear Quarter Belt Reveal	Optional			X			Rear Quarter Belt Reveal Corner Escutcheon	
9	Rear Quarter Belt Reveal Corner Escutcheon	Optional			X		X		
10	Rear Compartment Front Panel Grille Molding	Optional					X		Rear Compartment Front Panel Grille
11	Roof Panel Emblem	Optional					X		Headlining at Rear Quarter Area
12	Front Door Outer Panel	All	X		X				
13	Front of Rear Wheel Opening	All					X		Quarter Trim Pad
14	Rear Wheel Opening	All	X						
15	Rear Quarter Outer Panel Name Plate	All					X		Quarter Trim Pad

METHODS OF MOLDING RETENTION
 BUICK "E" BODIES - 49000 SERIES
 FIGURES 17-114 THROUGH 17-115

Key	Molding Name	Series or Styles	Screws	Spring (Self-Retained)	Snap-On Clips or Retainers On Panel	Snap-On Clips On Molding	Studs With Attaching Nuts	Engages With Other Moldings	Remove Hardware Or Trim
16	Back Window Reveal Upper	All			X				
17	Back Window Reveal Side	All			X			Back Window Reveal Upper	
18	Back Window Reveal Lower	All			X			Back Window Reveal Side	
19	Rear Compartment Lid Outer Panel Name Plate	All					X		
20	Rear Compartment Lid Outer Panel	All	X						
21	Rear of Rear Quarter Outer Panel	All	X				X		Tail Lamp Assembly

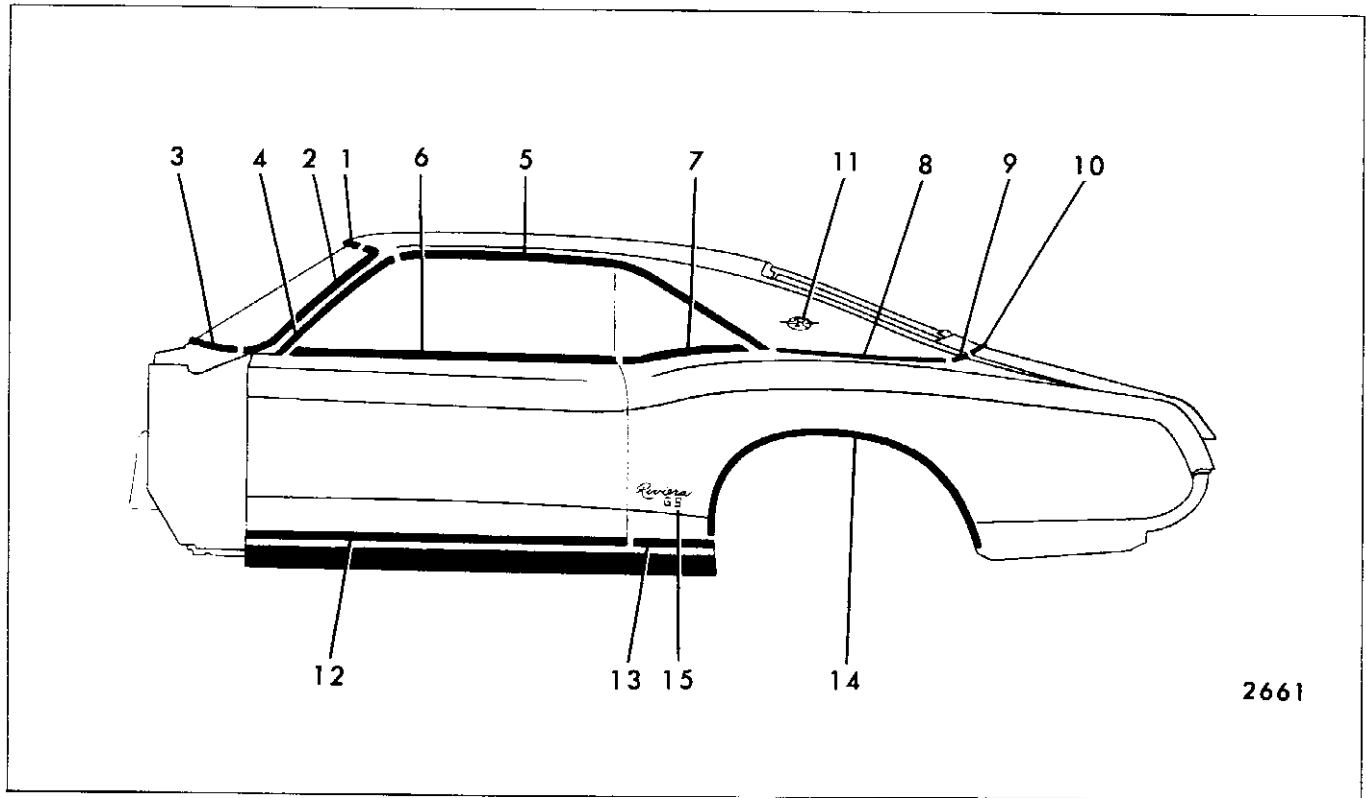

Fig. 17-114—Buick 49487 Styles

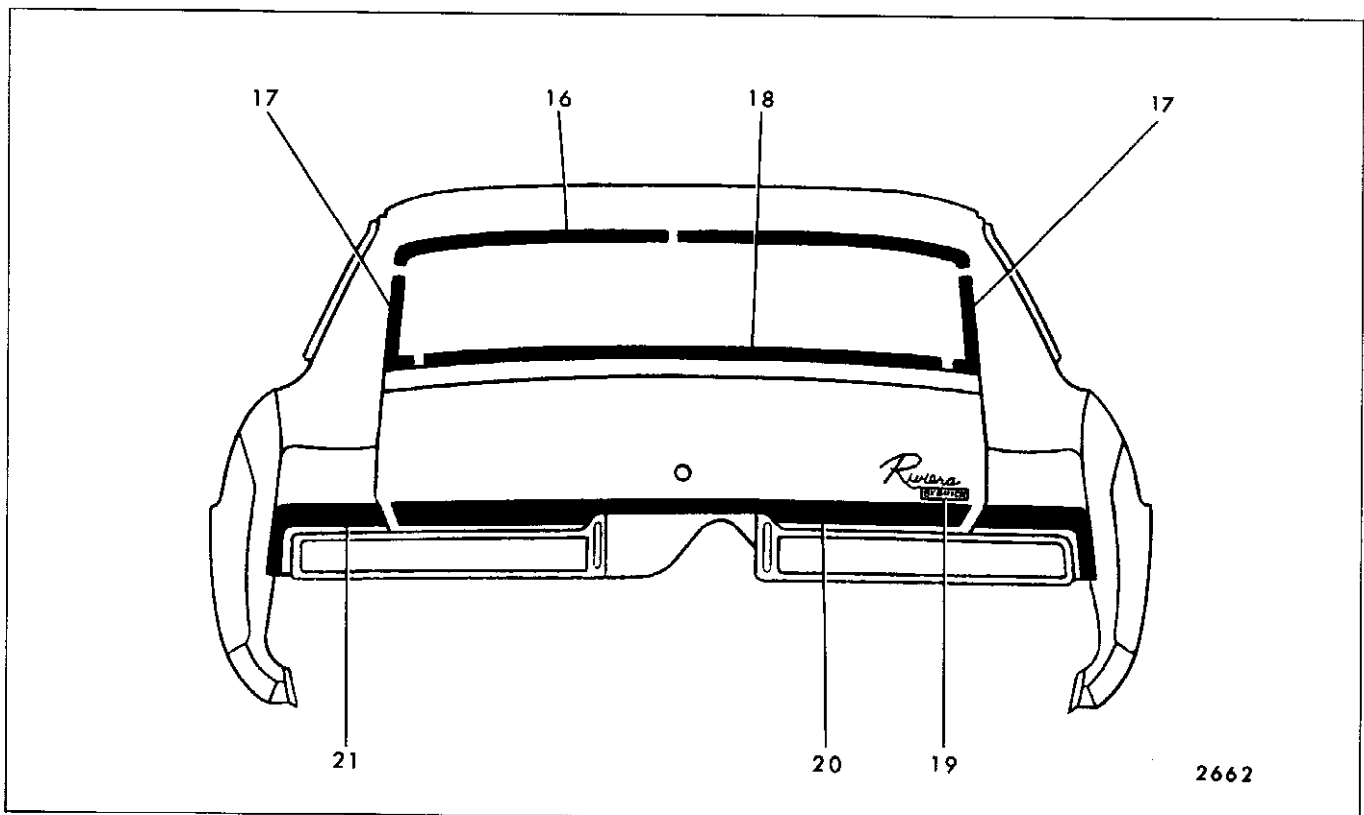

Fig. 17-115—Buick 49487 Styles