

METHODS OF MOLDING RETENTION  
 CADILLAC "C" BODIES - 68000 SERIES  
 FIGURES 17-116 THROUGH 17-122

Key	Molding Name	Series or Styles	Screws	Spring (Self-Retained)	Snap-On Clips or Retainers On Panel	Snap-On Clips On Molding	Studs With Attaching Nuts	Engages With Other Moldings	Remove Hardware Or Trim
1	Windshield Reveal Upper	All			X			Windshield Reveal Side	
2	Windshield Reveal Side	All			X			Windshield Reveal Lower	
3	Windshield Reveal Lower	All	X						Cowl Air Intake Grille
4	Windshield Pillar Drip	All (Except 67)	X						Windshield Pillar Weatherstrip and Weatherstrip Retainer
5	Windshield Pillar Finishing	67	X					Windshield Side Reveal	Windshield Pillar Weatherstrip and Weatherstrip Retainer
6	Windshield Header	67	X					Windshield Pillar Finishing Windshield Reveal Upper	Sunshade Support, Rear View Mirror Support
7	Roof Drip Molding Scalp	68269,68369		X				Windshield Pillar Drip	
8	Roof Drip Molding Front Scalp	68069,68169 68247-49 68347-49		X				Windshield Pillar Drip	
9	Roof Drip Molding Rear Scalp	68069,68169 68247-49 68347-49		X				Roof Drip Molding Front Scalp	
10	Roof Panel Cover Front Finish	68169	X		X			Roof Panel Cover Front Finish Escutcheon	Front Section of Headlining
11	Roof Panel Cover Front Finish Escutcheon	68169					X	Roof Panel Cover Side Front Finish	Front Section of Headlining
12	Roof Panel Cover Side Front Finish	68169			X		X	Roof Panel Cover Front Finish Escutcheon Roof Panel Cover Side Rear Finish	Headlining at Side Area

METHODS OF MOLDING RETENTION  
 CADILLAC "C" BODIES - 68000 SERIES  
 FIGURES 17-116 THROUGH 17-122

Key	Molding Name	Series or Styles	Screws	Spring (Self-Retained)	Snap-On Clips or Retainers On Panel	Snap-On Clips On Molding	Studs With Attaching Nuts	Engages With Other Moldings	Remove Hardware Or Trim
13	Roof Panel Cover Side Rear Finish	68169					X	Rear End Belt Cover Finish	Headlining at Rear Quarter Area
14	Roof Panel Emblem and/or Name Plate	68069 68169					X		Headlining at Rear Quarter Area
15	Rear End Belt Cover Finish	68169					X		Headlining at Rear Quarter Area
16	Center Pillar Scalp	68269 68369	X						Weatherstrip and Weatherstrip Retainer At Center Pillar
17	Rear Quarter Belt Reveal	68347-49-69			X	X	X		Headlining at Rear Quarter Area
18	Rear Quarter Belt Reveal Corner Escutcheon	68369					X	Rear Quarter Belt Reveal	
19	Rear End Belt Reveal	68369					X	Rear Quarter Belt Reveal Corner Escutcheon	
20	Rear Quarter Pinch Weld Finishing	67	X		X			Rear Quarter Window Belt Reveal	
21	Front Door Window Belt Reveal (at Vent)	All	X						Front Door Vent Assembly
22	Front Door Window Belt Reveal	All	X					Front Door Window Belt Reveal (at Vent)	Rubber Bumper on Front Door Window Lower Stop
23	Rear Door Window Belt Reveal	49,69	X						Rubber Bumper on Rear Door Window Lower Stop
24	Rear Quarter Window Belt Reveal	47,67	X						Rear Quarter Window Lower Stop
25	Front Door Outer Panel	68200 68300	X		X		X		

METHODS OF MOLDING RETENTION  
 CADILLAC "C" BODIES - 68000 SERIES  
 FIGURES 17-116 THROUGH 17-122

Key	Molding Name	Series or Styles	Screws	Spring (Self-Retained)	Snap-On Clips or Retainers On Panel	Snap-On Clips On Molding	Studs With Attaching Nuts	Engages With Other Moldings	Remove Hardware Or Trim
26	Rear Door Outer Panel	68200 68300	X		X		X		
27	Rear Quarter Outer Panel	68247 68347-67  68249-69 68349-69				X	X		Rear Quarter Trim Pad Rear Compartment Side Trim
28	Rear Quarter Outer Panel Name Plate and/or Emblem	All				X	X		Rear Compartment Side Trim
29	Rear of Rear Wheel Opening	68069 68169	X		X				
30	Rear of Rear Quarter Outer Panel Outer at Tail Lamp	68069 68169	X					Rear of Rear Wheel Opening	Rear Bumper Assembly
31	Rear of Rear Quarter Outer Panel Inner at Tail Lamp	68069 68169	X					Rear of Rear Quarter Outer Panel Outer at Tail Lamp	Rear Bumper Assembly
32	Rear of Rear Quarter Outer Panel at Compartment Lid	All	X				X	Rear of Rear Quarter Outer Panel Inner at Tail Lamp (68069, 68169 Styles Only)	
33	Rear Compartment Lid Outer Panel	All	X						
34	Back Window Reveal Upper	All			X			Back Window Reveal Side	
35	Back Window Reveal Side	68200,68300  68069,68169			X			Back Window Reveal Lower Back Window Reveal Lower Corner Escutcheon	
36	Back Window Reveal Lower	All			X			Back Window Reveal Lower Corner Escutcheon (68069, 68169 Styles)	
37	Back Window Reveal Lower Corner Escutcheon	68069 68169			X				
38	Rear Compartment Lid Outer Panel Emblem and/or Name Plate	All					X		

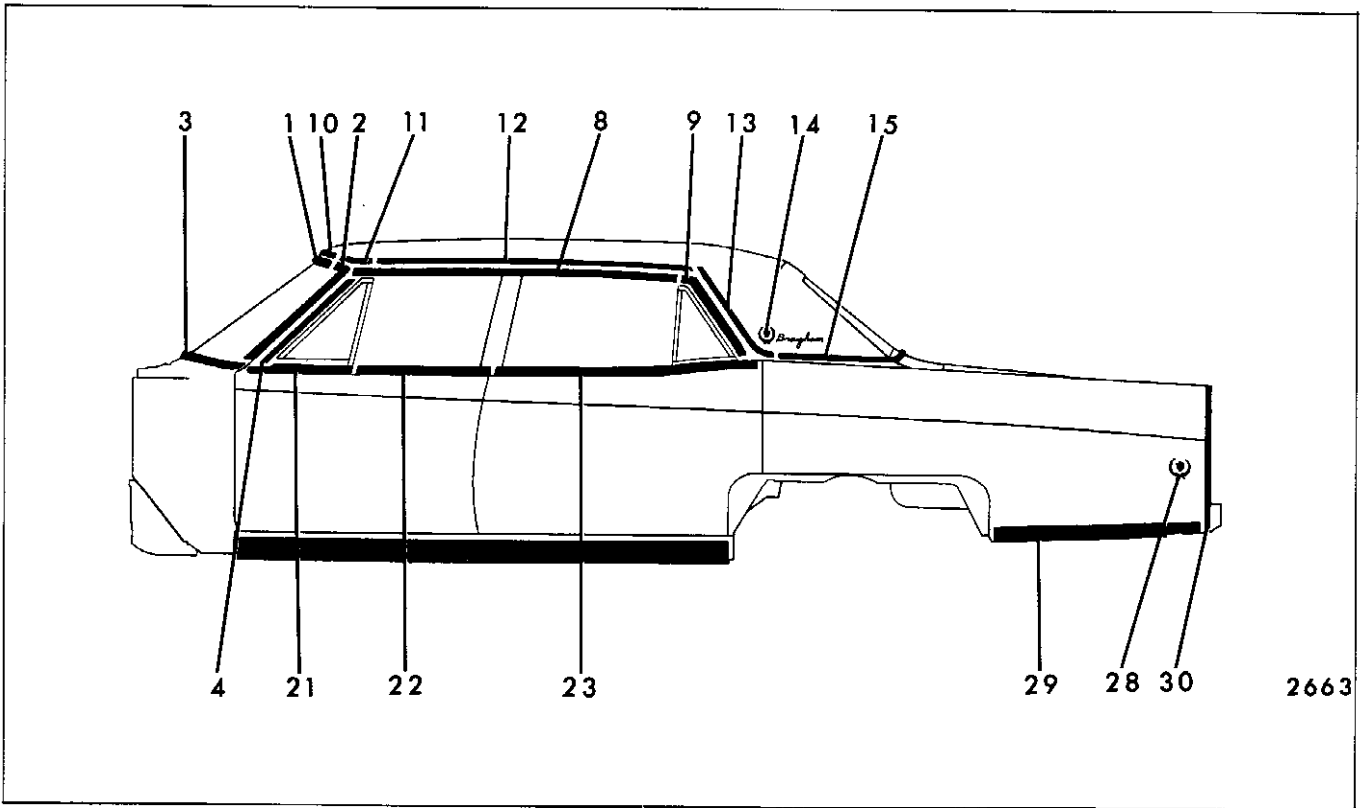

Fig. 17-116—Cadillac 68069-68169 Styles

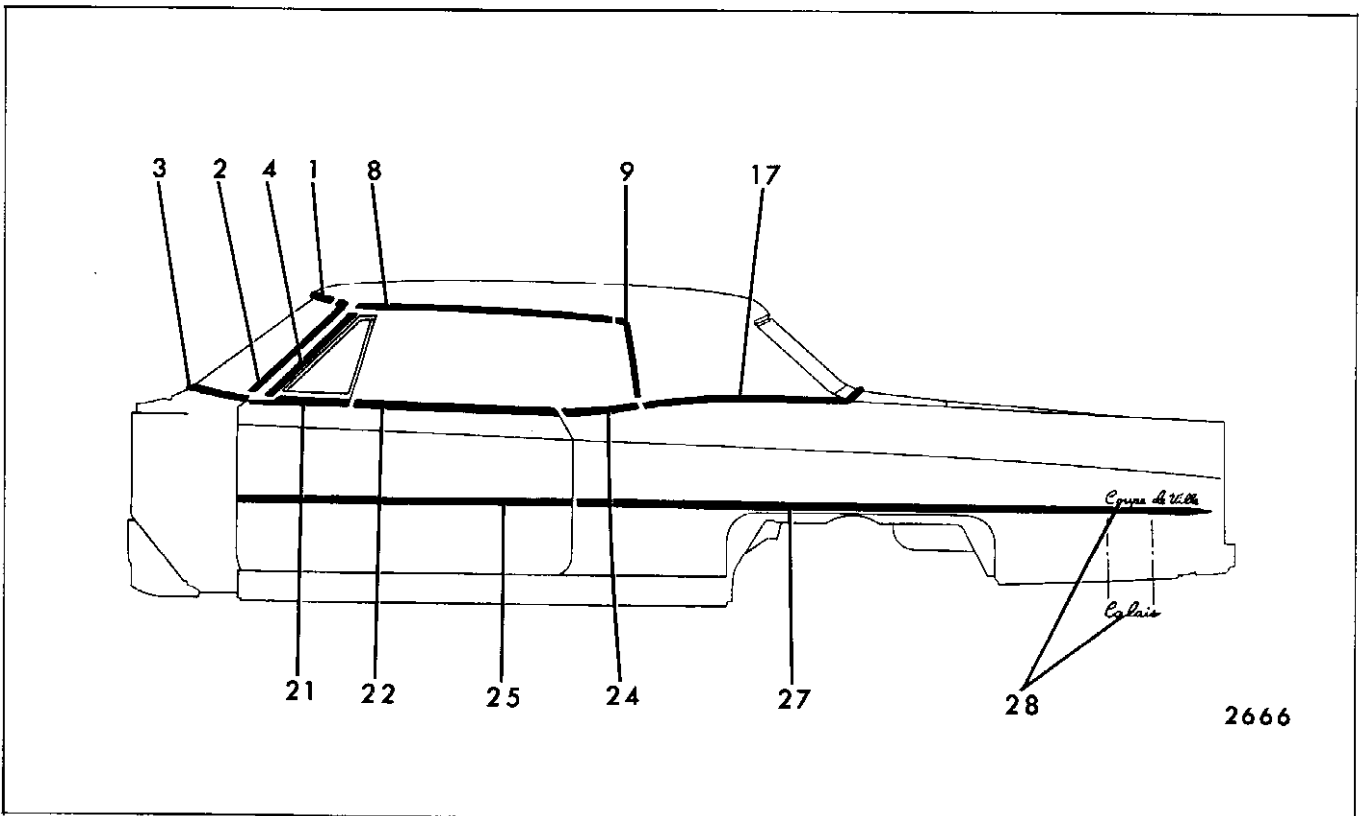

Fig. 17-117—Cadillac 68247-68347 Styles

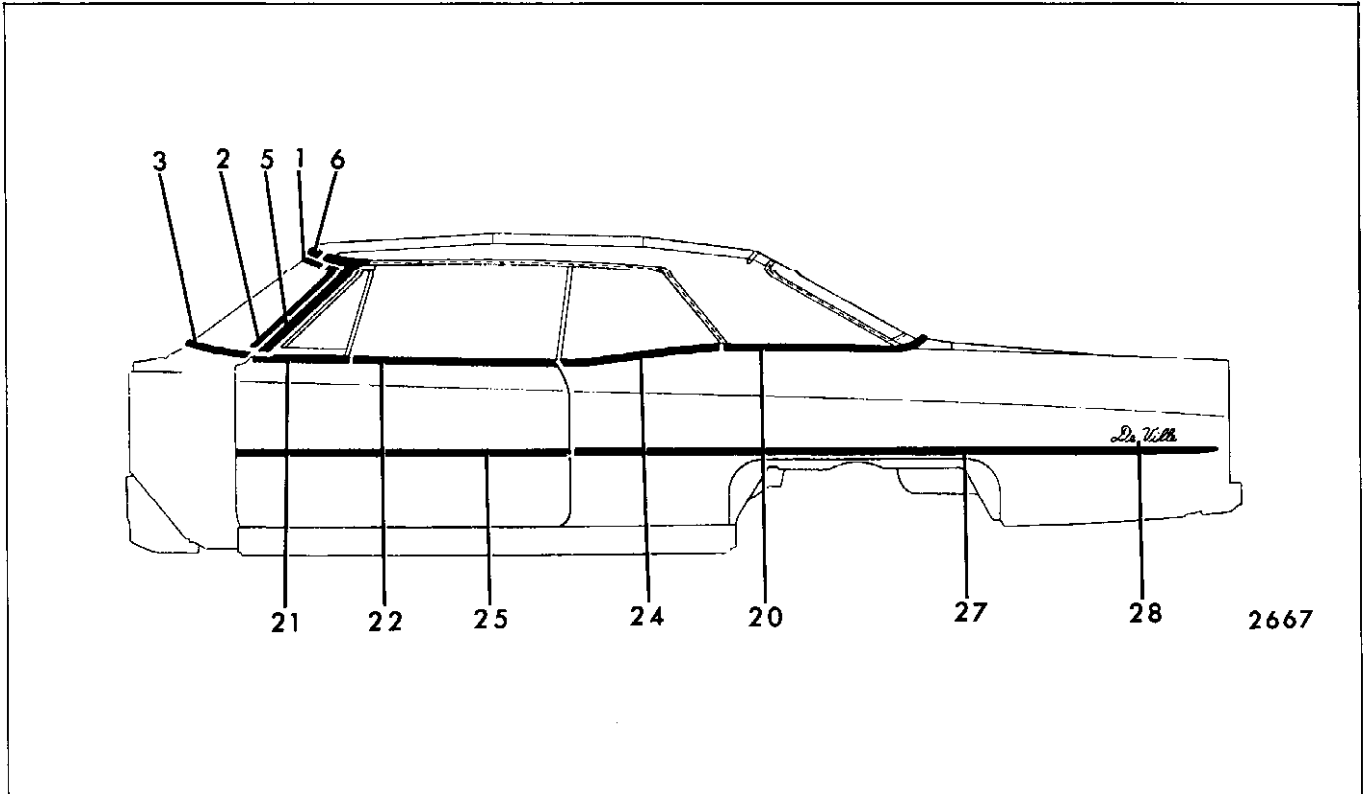

Fig. 17-118—Cadillac 68367 Styles

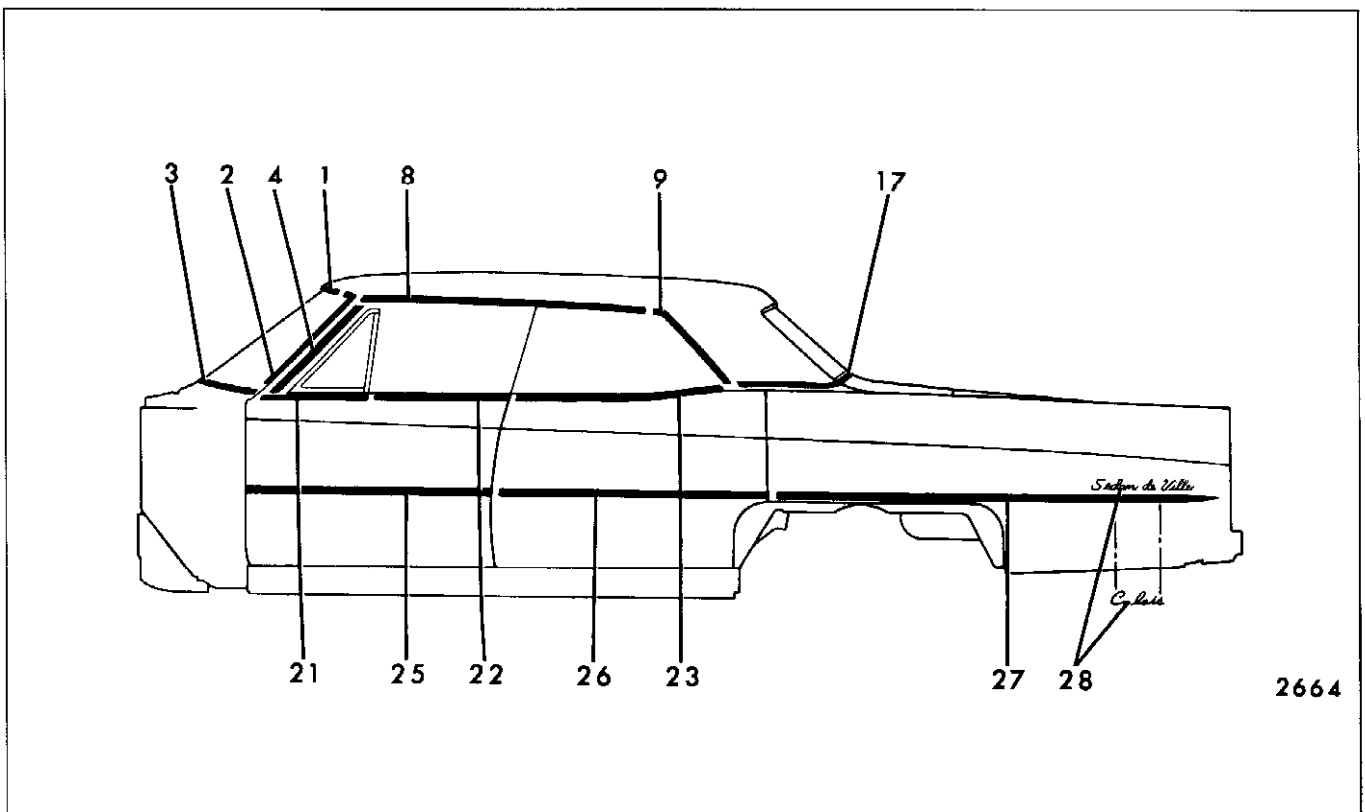

Fig. 17-119—Cadillac 68249-68349 Styles

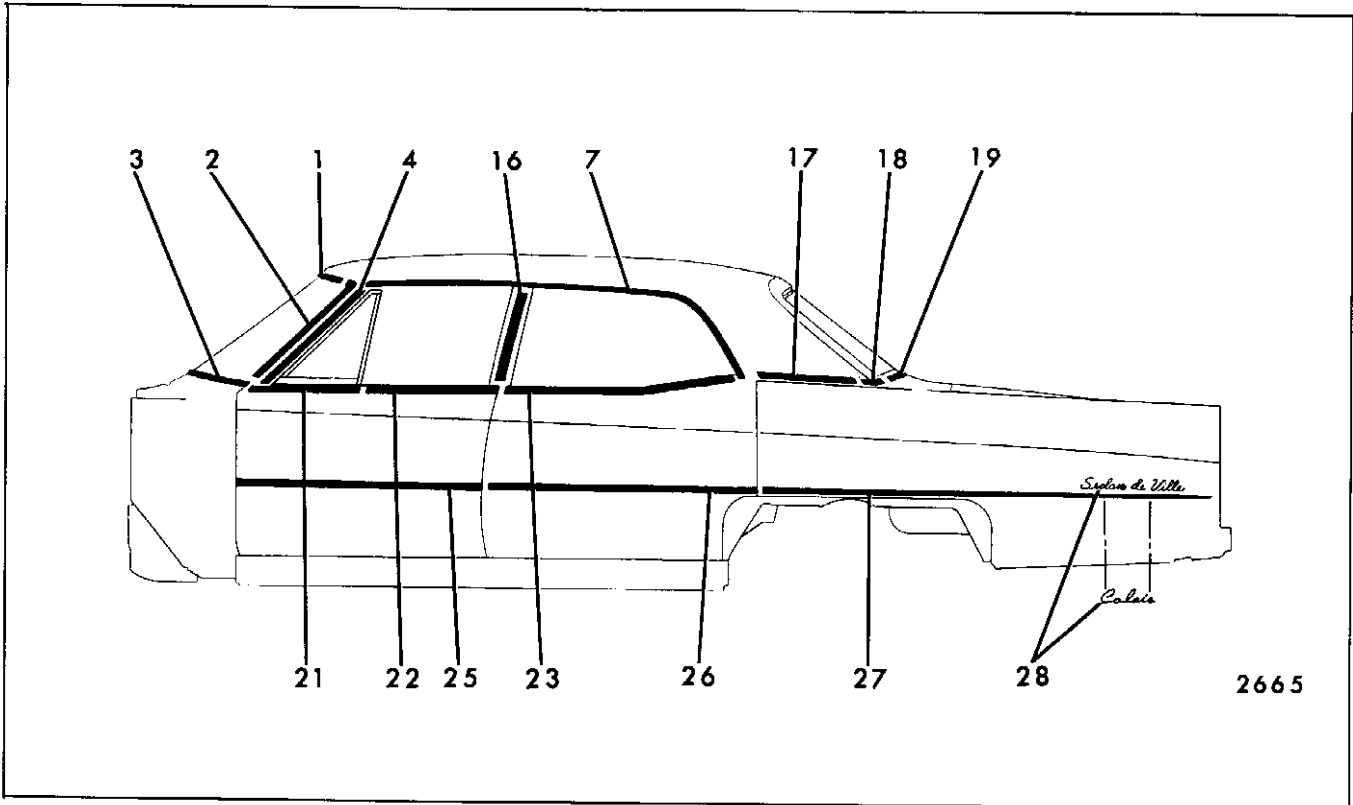

Fig. 17-120—Cadillac 68269-68369 Styles

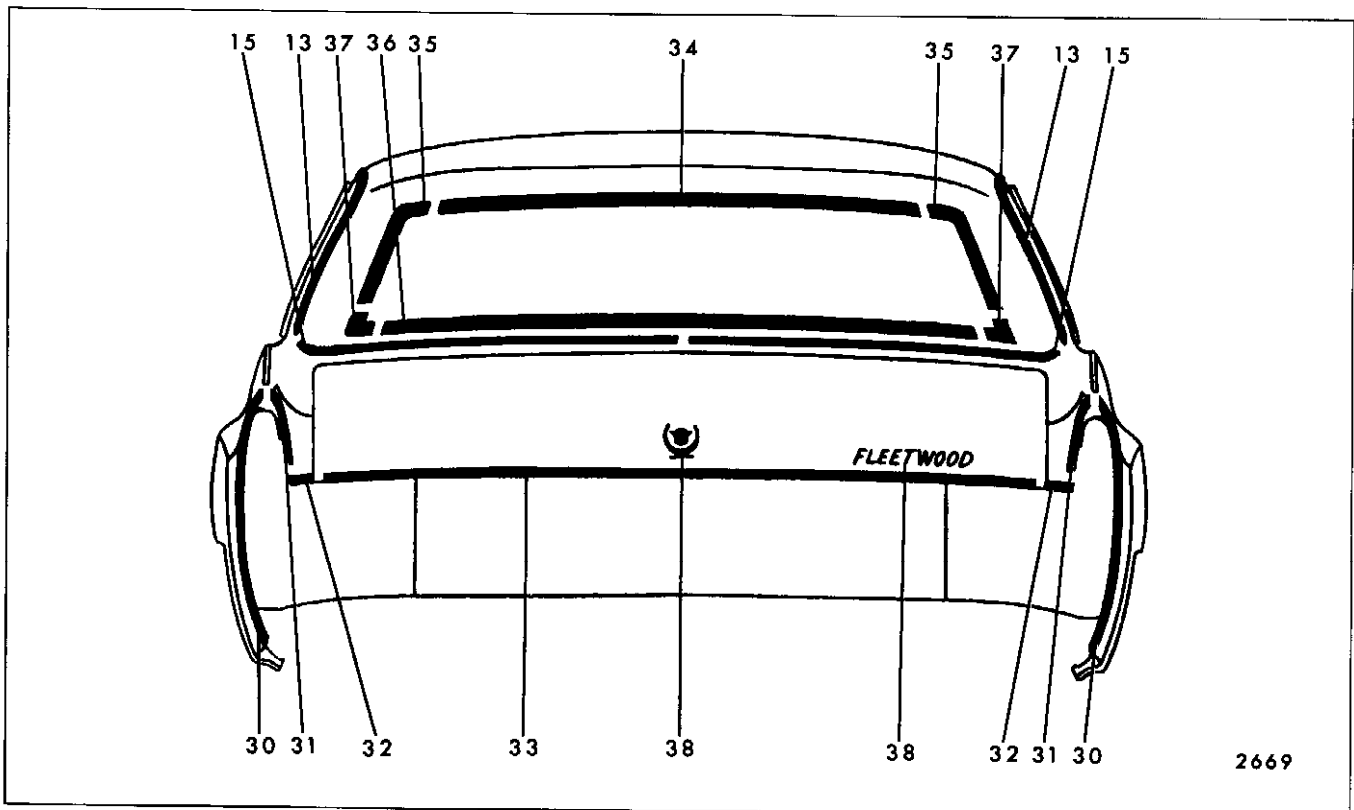

Fig. 17-121—Cadillac 68069-68169 Styles

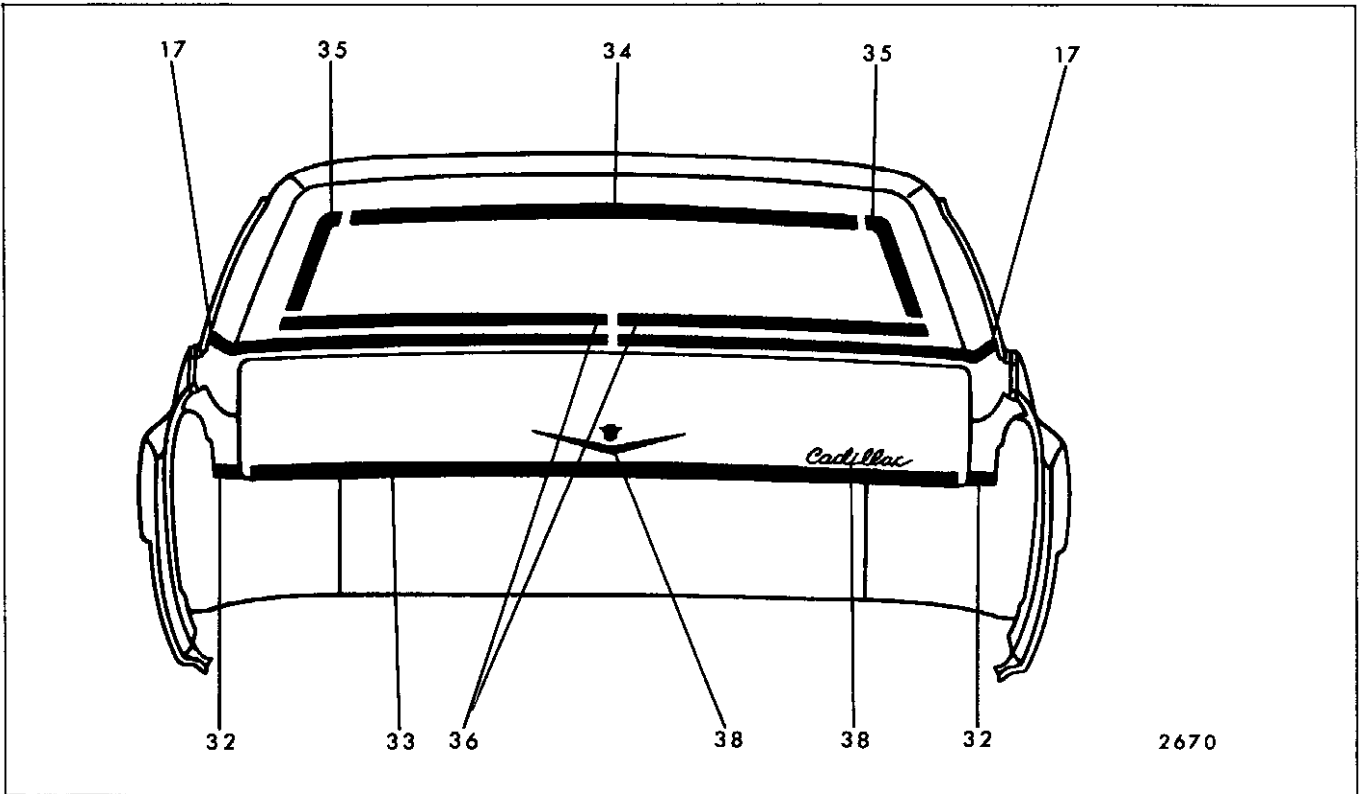

Fig. 17-122—Cadillac 68200-68300 Styles