

METHODS OF MOLDING RETENTION
 CHEVROLET "F" BODIES - 12000 SERIES
 FIGURES 17-28 AND 17-29

Key	Molding Name	Series or Styles	Screws	Spring (Self-Retained)	Snap-On Clips or Retainers On Panel	Snap-On Clips On Molding	Studs With Attaching Nuts	Engages With Other Moldings	Remove Hardware Or Trim
1	Windshield Reveal Upper	All			X			Windshield Reveal Side	
2	Windshield Reveal Side	All			X			Windshield Reveal Lower	
3	Windshield Reveal Lower	All	X						Cowl Air Intake Grille
4	Windshield Pillar Drip Molding Scalp	12637	X					Windshield Pillar Drip Molding Scalp Escutcheon	Windshield Pillar Weatherstrip and Weatherstrip Retainer
5	Windshield Pillar Drip Molding Scalp Escutcheon	12637		X					
6	Roof Drip Molding Scalp	12637		X				Windshield Pillar Drip Molding Scalp Escutcheon	
7	Windshield Pillar Finishing	67 Styles	X						Windshield Pillar Weatherstrip and Weatherstrip Retainer
8	Windshield Header	67 Styles	X					Windshield Reveal Upper and Sides Windshield Pillar Weatherstrip and Retainer	Rear View Mirror Support Sunshade and Striker Support
9	Rear Quarter Belt Reveal	37 Styles (Optional)			X		X		
10	Rear Quarter Pinch Weld Finishing	67 Styles	X			X			
11	Front Door Outer Panel	All (Optional)	X				X		Front Door Trim Pad
12	Rear Wheel Opening	12600 (Optional)	X						
13	Back Window Reveal Upper	37 Styles			X			Back Window Reveal Side	
14	Back Window Reveal Side	37 Styles			X			Back Window Reveal Lower	
15	Back Window Reveal Lower	37 Styles			X				

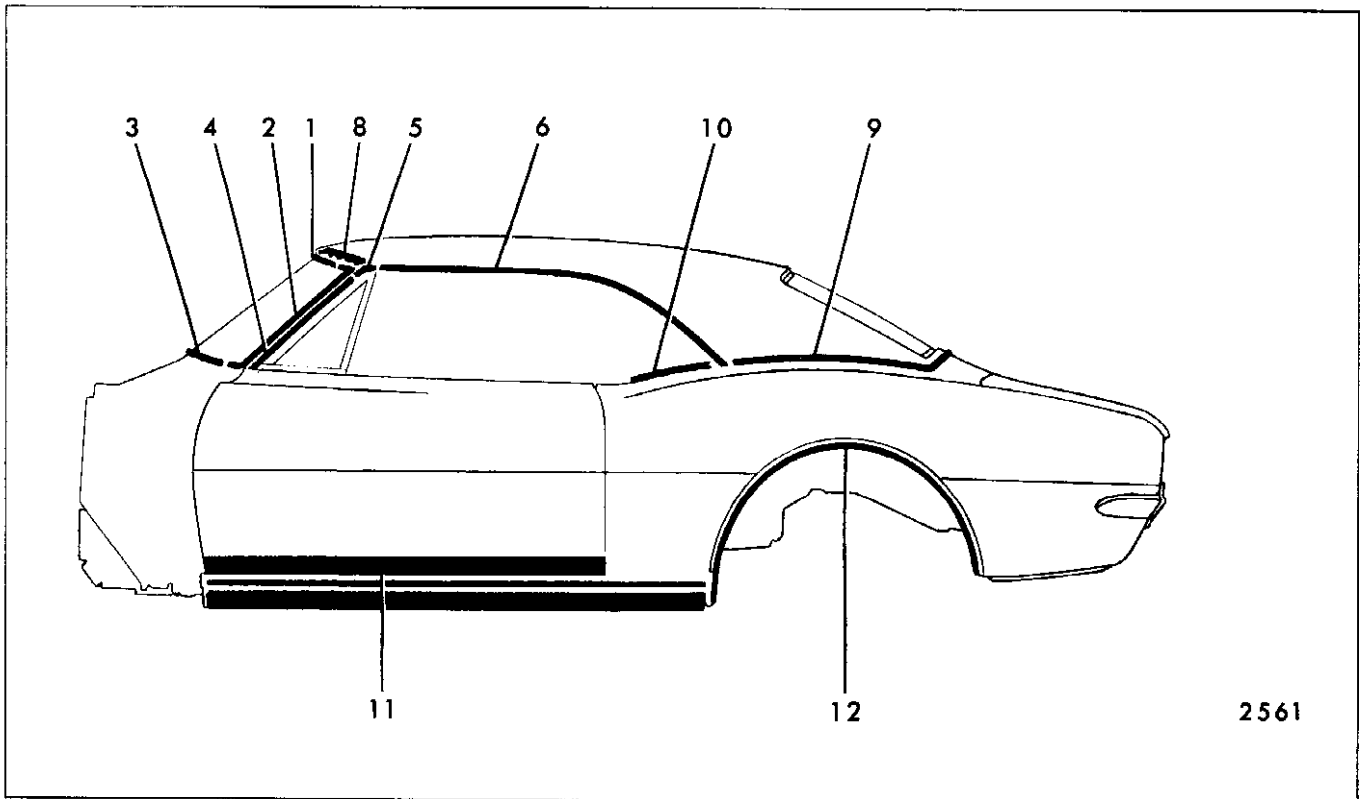

Fig. 17-28—Chevrolet "F-37-67" Styles

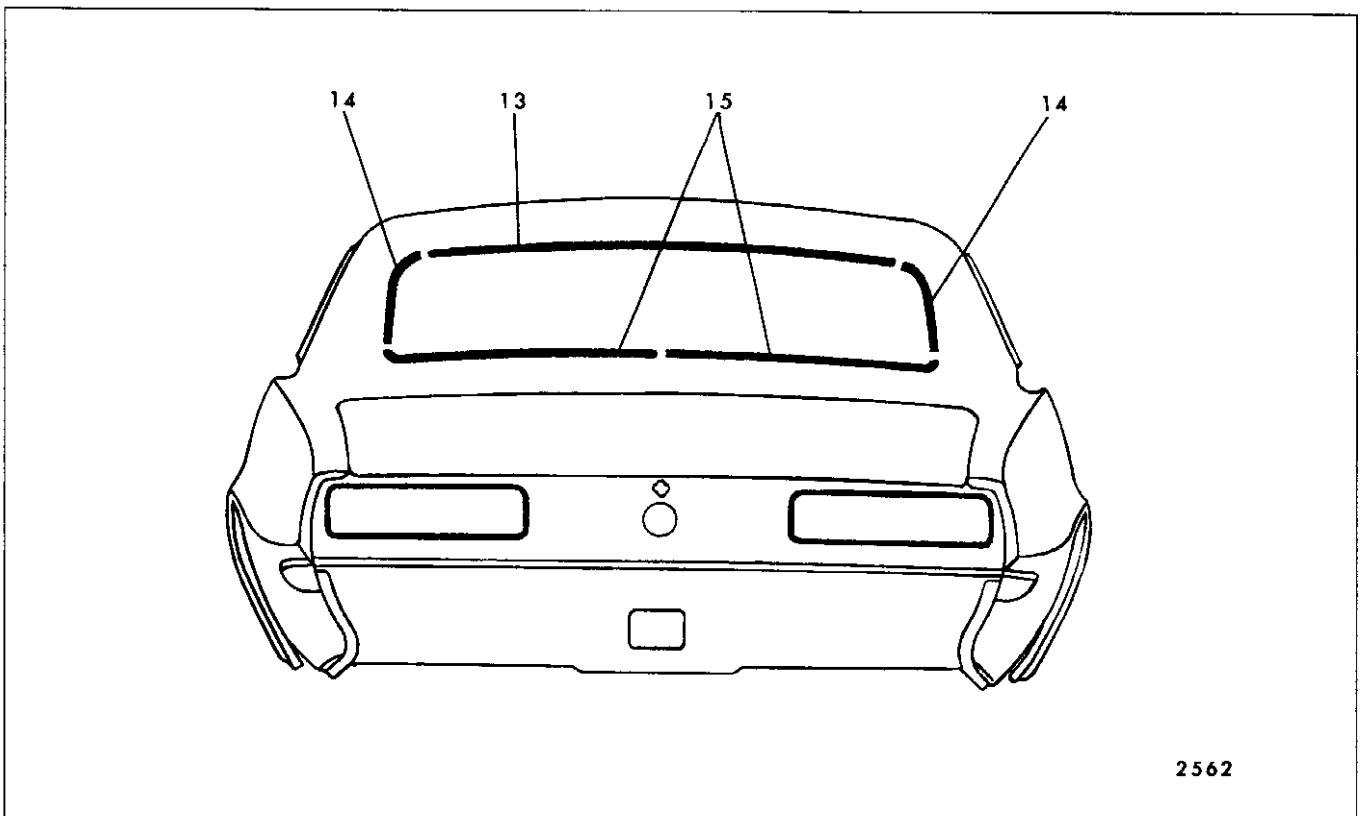

Fig. 17-29—Chevrolet "F-37-67" Styles