

METHODS OF MOLDING RETENTION
 CHEVROLET "Z" BODIES - 10000 SERIES
 FIGURES 17-36 THROUGH 17-39

Key	Molding Name	Series or Styles	Screws	Spring (Self-Retained)	Snap-On Clips or Retainers On Panel	Snap-On Clips On Molding	Studs With Attaching Nuts	Engages With Other Moldings	Remove Hardware Or Trim
1	Front End Outer Panel	All					X		Front Compartment Lock Cylinder and Retainer
2	Front End Outer Panel Name Plate	All					X		
3	Front Wheel Opening	10500	X						
4	Front Fender Emblem	All			X		X		Front Cowl Trim Foundation
5	Windshield Reveal Upper	All			X				
6	Windshield Reveal Side	All			X			Windshield Reveal Upper	
7	Windshield Reveal Lower	All			X			Windshield Reveal Side	
8	Windshield Pillar Drip Molding Scalp	10500		X				Windshield Pillar Drip Molding Scalp Escutcheon	
9	Windshield Pillar Drip Molding Scalp Escutcheon	10500		X					
10	Roof Drip Molding Scalp	10500		X				Windshield Pillar Drip Molding Scalp Escutcheon	
11	Rocker Outer Panel	10500	X		X				
12	Rear Wheel Opening	10500	X						
13	Rear Quarter Belt Reveal (Optional)	39 Styles			X		X		
14	Back Window Reveal Upper	All			X			Back Window Reveal Sides	
15	Back Window Reveal Side	37 Styles 39 Styles			X X			Back Window Reveal Lower	
16	Back Window Reveal Lower	37 Styles 39 Styles			X X			Back Window Reveal Sides	

METHODS OF MOLDING RETENTION
 CHEVROLET "Z" BODIES - 10000 SERIES
 FIGURES 17-36 THROUGH 17-39

Key	Molding Name	Series or Styles	Screws	Spring (Self-Retained)	Snap-On Clips or Retainers On Panel	Snap-On Clips On Molding	Studs With Attaching Nuts	Engages With Other Moldings	Remove Hardware Or Trim
17	Rear of Rear Quarter	All					X		
18	Rear of Rear Quarter Finishing	10500	X						Rear of Rear Quarter Molding
19	Engine Compartment Lid	10500	X						
20	Engine Compartment Lid Name Plate	All					X		
21	Rear End Panel	10500					X	Rear of Rear Quarter Finishing	

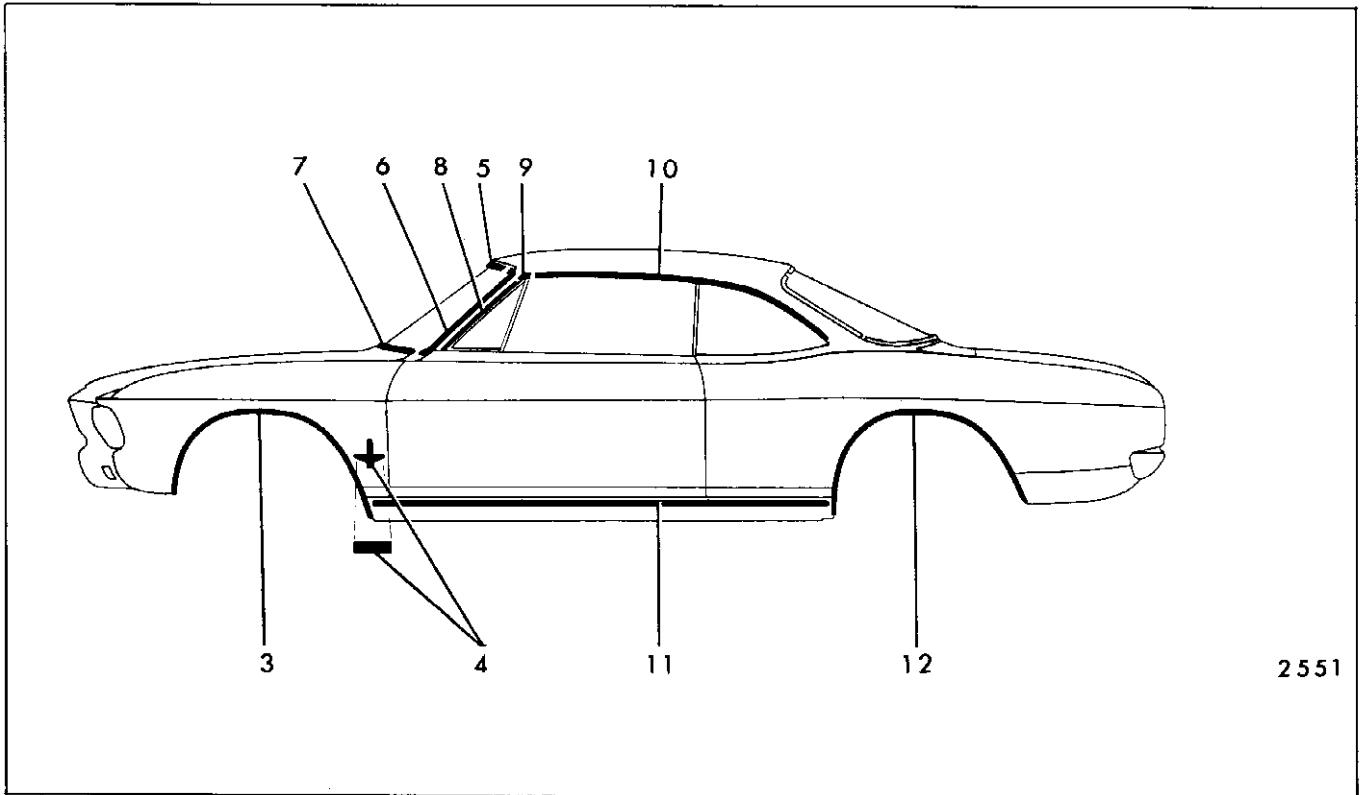

Fig. 17-36—Chevrolet "Z-37" Styles

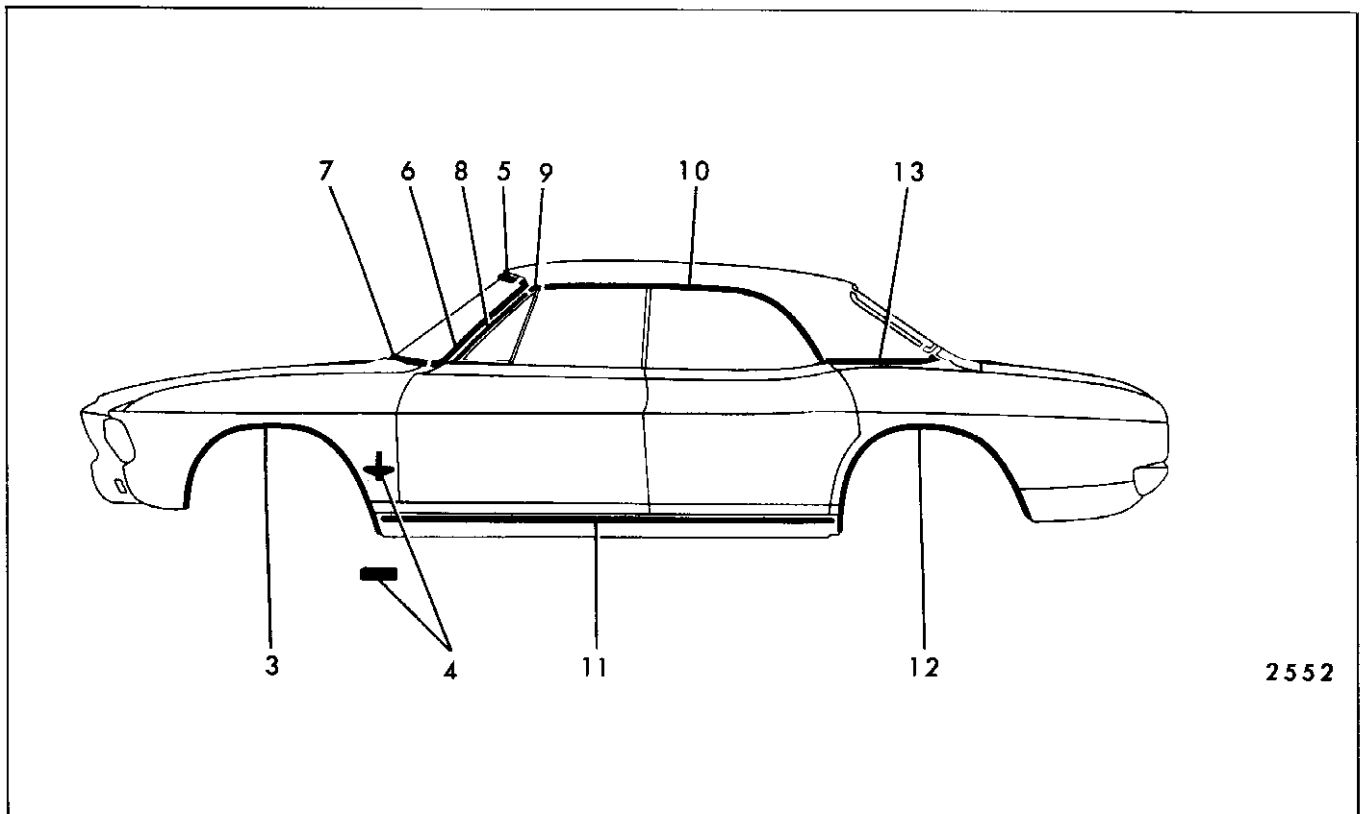

Fig. 17-37—Chevrolet "Z-39" Styles

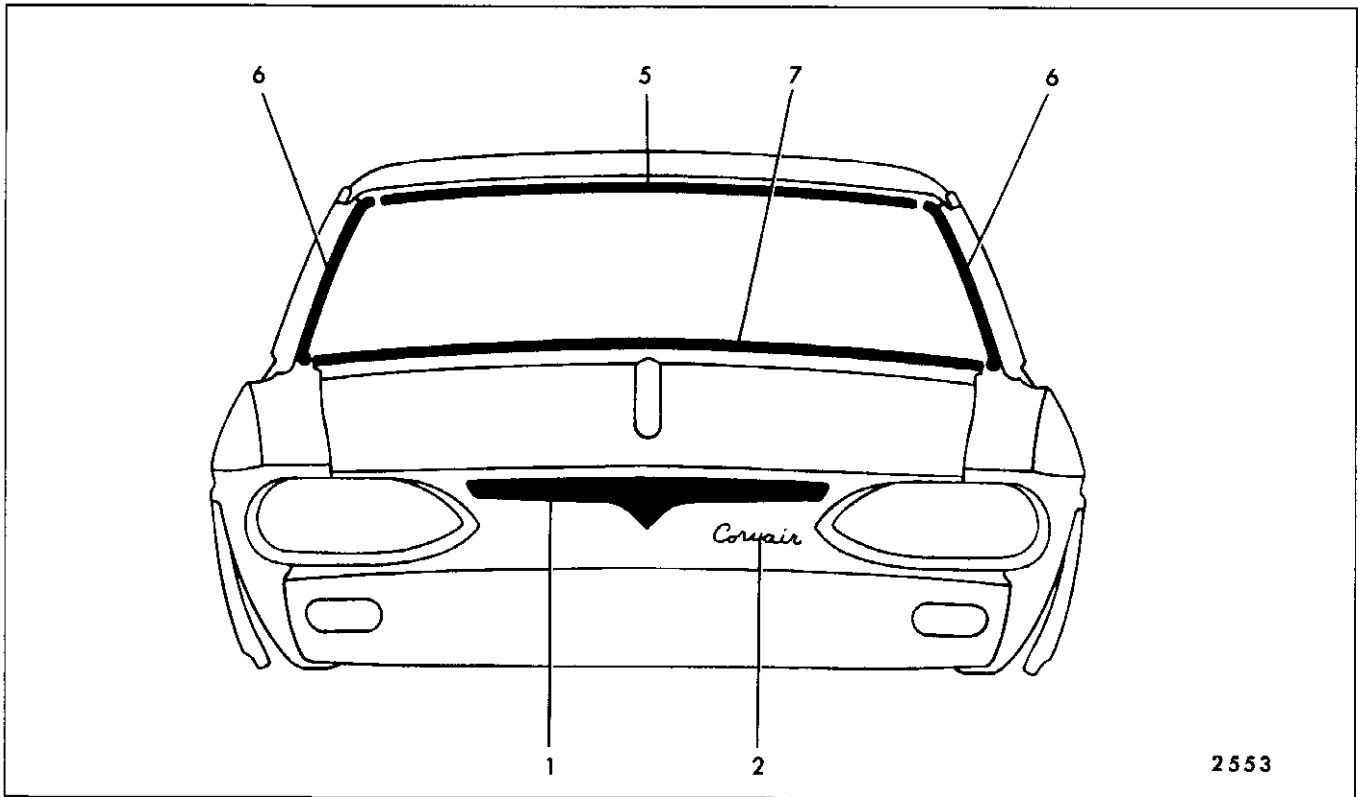

Fig. 17-38—Chevrolet "Z-37-39" Styles

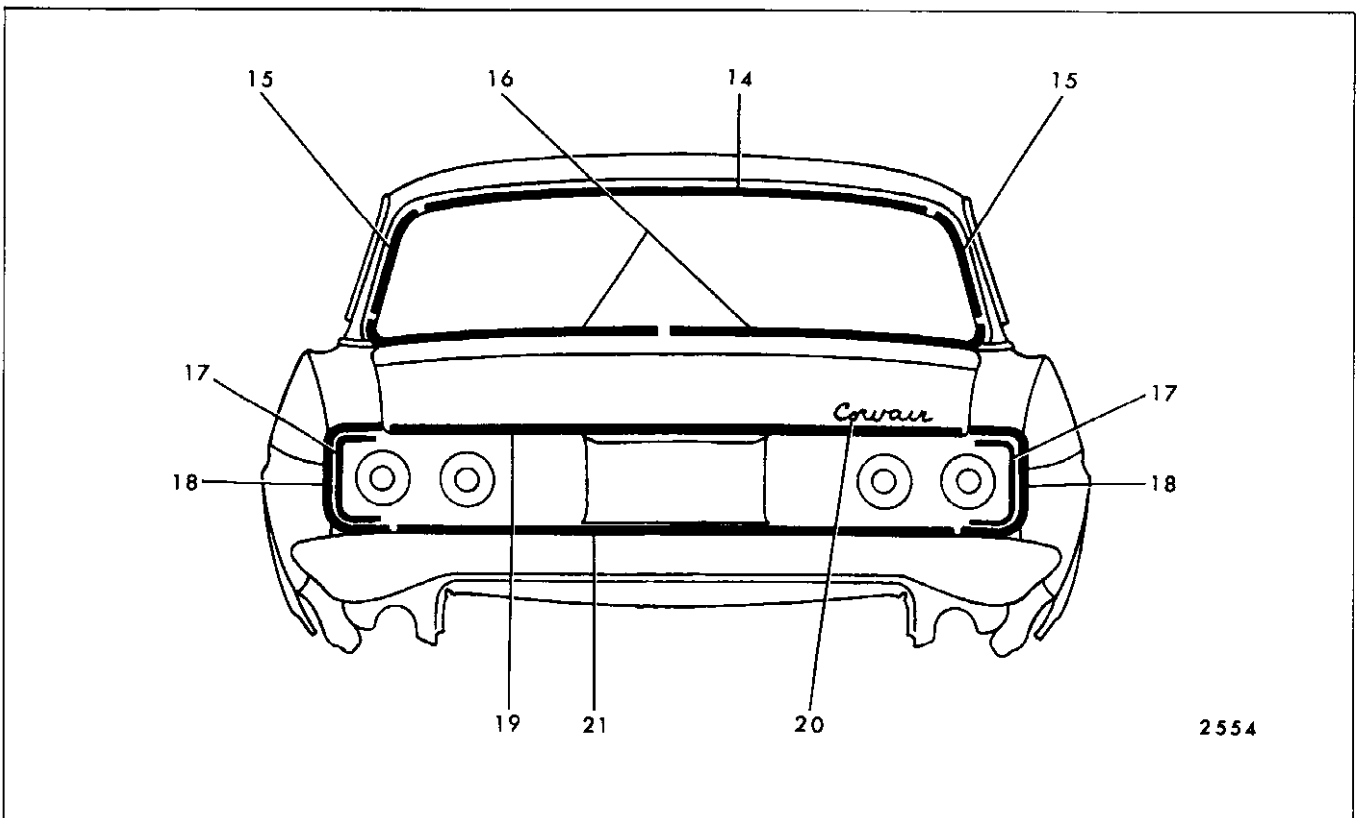

Fig. 17-39—Chevrolet "Z-37-39" Styles