

**METHODS OF MOLDING RETENTION**  
**PONTIAC "B" BODIES - 25000 AND 26000 SERIES**  
**FIGURES 17-50 THROUGH 17-66**

Key	Molding Name	Series or Styles	Screws	Spring (Self-Retained)	Snap-On Clips or Retainers On Panel	Snap-On Clips On Molding	Studs With Attaching Nuts	Engages With Other Moldings	Remove Hardware Or Trim
1	Windshield Reveal Upper	All			X			Windshield Reveal Side	
2	Windshield Reveal Side	All			X				
3	Windshield Reveal Lower	All	X						Cowl Air Intake Grille
4	Windshield Pillar Drip	All (Except 67)	X						Windshield Pillar Weatherstrip and Weatherstrip Retainer
5	Windshield Pillar Finishing	67	X					Windshield Side Reveal	Windshield Pillar Weatherstrip and Weatherstrip Retainer
6	Windshield Header	67	X					Windshield Reveal Upper and Sides Windshield Pillar Finishing	Rear View Mirror Support Sunshade Support
7	Roof Drip Molding Scalp	39,69,87		X				Windshield Pillar Drip	
8	Roof Drip Molding Scalp Front	35,45,57		X				Windshield Pillar Drip	
9	Roof Drip Molding Scalp Rear	35,45,57		X				Roof Drip Molding Scalp Front	
10	Roof Panel Name Plate	26239-87					X		Headlining Rear Quarter Trim
11	Front Door Window Frame Front Scalp	11,35,45,69		X					
12	Front Door Window Frame Upper Scalp	11,35,45,69		X				Front Door Window Frame Front Scalp	
13	Front Door Window Frame Rear Scalp	11,35,45,69		X				Front Door Window Frame Upper Scalp	
14	Front Door Window Belt Reveal (at Vent)	All (Except 26657)	X						Front Door Vent Assembly

METHODS OF MOLDING RETENTION  
PONTIAC "B" BODIES - 25000 AND 26000 SERIES  
FIGURES 17-50 THROUGH 17-66

Key	Molding Name	Series or Styles	Screws	Spring (Self-Retained)	Snap-On Clips or Retainers On Panel	Snap-On Clips On Molding	Studs With Attaching Nuts	Engages With Other Moldings	Remove Hardware Or Trim
15	Front Door Window Belt Reveal	26600	X					Front Door Window Belt Reveal (at Vent) (67 Style Only)	Rubber Bumper on Door Glass Lower Stop
16	Rear Door Window Frame Front Scalp	35,45,69		X				Rear Door Window Frame Upper Scalp	
17	Rear Door Window Frame Upper Scalp	35,45,69		X				Rear Door Window Frame Rear Scalp	
18	Rear Door Window Frame Rear Scalp	35,45		X					
19	Rear Quarter Window Reveal Upper	11	X						
20	Rear Quarter Window Reveal Front	11			X			Rear Quarter Window Reveal Upper	
21	Rear Quarter Window Belt Reveal	26600	X						Rear Quarter Window Glass Lower Stop
22	Rear Quarter Belt Reveal Front	57,87			X		X	Rear End Belt Reveal	
23	Rear End Belt Reveal	57,87			X		X		
24	Rear Quarter Belt Reveal	11,39,69			X	X			
25	Rear Quarter Pinch-weld Finishing Molding	67	X		X				
26	Rear Quarter Window Reveal Upper	35,45			X			Rear Quarter Window Reveal Lower	
27	Rear Quarter Window Reveal Lower	35,45			X			Rear Quarter Window Reveal Lower Escutcheon	
28	Rear Quarter Window Reveal Lower Escutcheon	35,45			X			Loosen Rear Quarter Window Reveal Upper and Lower	
29	Front Door Outer Panel	All (Except 25635-45)	X		X				

METHODS OF MOLDING RETENTION  
PONTIAC "B" BODIES - 25000 AND 26000 SERIES  
FIGURES 17-50 THROUGH 17-66

Key	Molding Name	Series or Styles	Screws	Spring (Self-Retained)	Snap-On Clips or Retainers On Panel	Snap-On Clips On Molding	Studs With Attaching Nuts	Engages With Other Moldings	Remove Hardware Or Trim
30	Rear Door Outer Panel	All (Except 25635-45)	X		X				
31	Rear Quarter Outer Panel	25200 25600 (Except 25635-45)				X	X		
32	Front of Rear Wheel Opening	26200	X		X				
33	Rear of Rear Wheel Opening	25635-45 26200 26600	X		X				
34	Rear of Rear Quarter Outer Panel	All (Except 35,45) 26245	X			X			
35	Rear Compartment Lid Outer Panel Emblem and/or Name Plate	All					X		
36	Rear End Panel Name Plate	All					X		
37	Rear Quarter Outer Panel Emblem and/or Name Plate	All					X		Quarter Trim on 26245 Styles
38	Front Door Outer Panel Transfer Finishing Upper	25635-45	X			X		Front Door Outer Panel Upper Insert	
39	Front Door Outer Panel Upper Insert	25635-45	X		X				
40	Front Door Outer Panel Transfer Finishing Lower	25635-45	X						
41	Rear Door Outer Panel Transfer Finishing Upper	25635-45	X			X		Rear Door Outer Panel Upper Insert	
42	Rear Door Outer Panel Upper Insert	25635-45	X		X				
43	Rear Door Outer Panel Transfer Finishing Lower	25635-45	X						

METHODS OF MOLDING RETENTION  
PONTIAC "B" BODIES - 25000 AND 26000 SERIES  
FIGURES 17-50 THROUGH 17-66

Key	Molding Name	Series or Styles	Screws	Spring (Self-Retained)	Snap-On Clips or Retainers On Panel	Snap-On Clips On Molding	Studs With Attaching Nuts	Engages With Other Moldings	Remove Hardware Or Trim
44	Rear Quarter Outer Panel Transfer Finishing	25635-45	X			X		Rear Quarter Outer Panel Insert	
45	Rear Quarter Outer Panel Insert	25635-45			X				
46	Rear Quarter Outer Panel Transfer Finishing Front	25635-45	X						
47	Rear Quarter Outer Panel Transfer Finishing Rear	25635-45	X						Loosen Rear Bumper
48	Back Window Reveal Upper	All (Except 35,45,67)			X			Back Window Reveal Side	
49	Back Window Reveal Side	All (Except 35,45,67)			X			Back Window Reveal Lower	
50	Back Window Reveal Lower	All (Except 35,45,67)			X			Back Window Reveal Side	
51	Back Body Opening Reveal Upper	35,45	X					Back Body Opening Reveal Side	Tailgate Glass Run Channel
52	Back Body Opening Reveal Side	35,45	X					Back Body Opening Reveal Upper	
53	Tailgate Window Reveal	35,45	X			X			
54	Tailgate Outer Panel Belt Reveal (Optional)	35,45	X			X			
55	Tailgate Outer Panel Emblem and/or Name Plate	35,45					X		Tailgate Trim Assembly
56	Tailgate Outer Panel Lower	25235-45	X				X		Tailgate Trim Assembly
		25635-45	X						
		26245	X			X			
57	Back Body Pillar Belt Reveal (Optional)	35,45	X			X			

METHODS OF MOLDING RETENTION  
 PONTIAC "B" BODIES - 25000 AND 26000 SERIES  
 FIGURES 17-50 THROUGH 17-66

Key	Molding Name	Series or Styles	Screws	Spring (Self-Retained)	Snap-On Clips or Retainers On Panel	Snap-On Clips On Molding	Studs With Attaching Nuts	Engages With Other Moldings	Remove Hardware Or Trim
58	Tailgate Outer Panel Transfer Finishing	25635-45	X			X		Tailgate Outer Panel Insert	
59	Tailgate Outer Panel Insert	25635-45			X				
60	Rear End Panel Lower	25600					X	Rear End Panel Lower Molding Escutcheon	
61	Rear End Panel Upper	25200,25600					X		
62	Rear End Panel	26200 26600					X X	Rear of Rear Quarter Outer Panel	
63	Rear End Panel Lower Molding Escutcheon	25600		X					

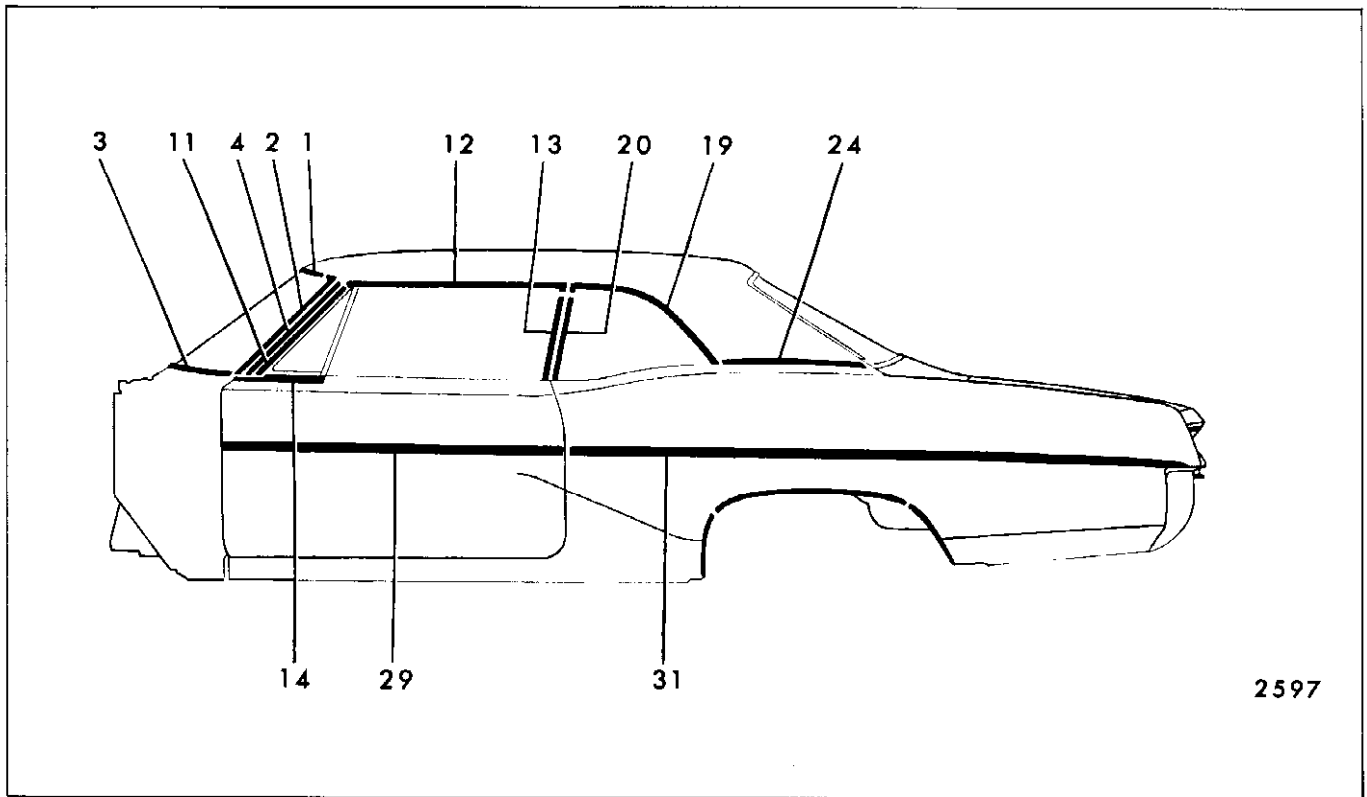

Fig. 17-50--Pontiac "B-11" Styles

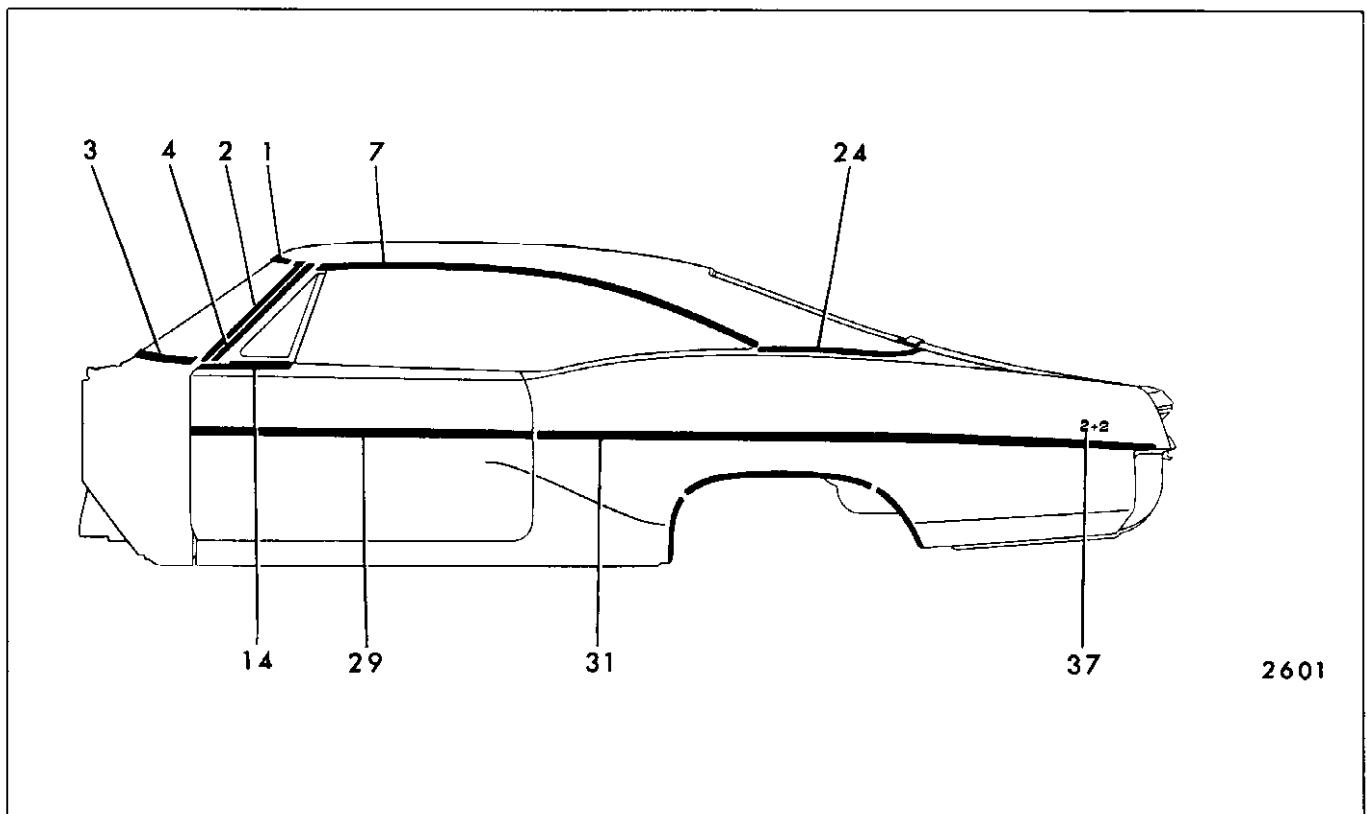

Fig. 17-51--Pontiac 25287-25687 Styles

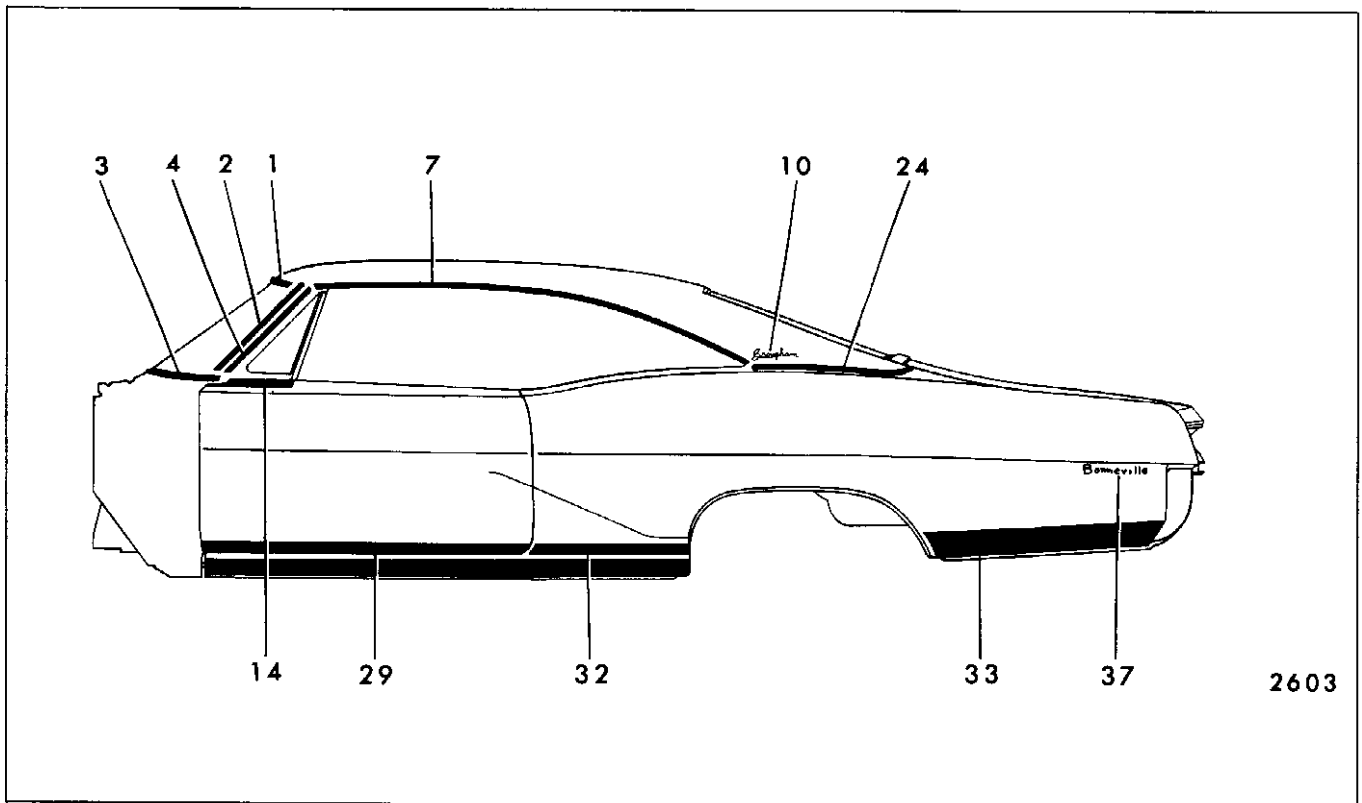

Fig. 17-52—Pontiac 26287 Styles

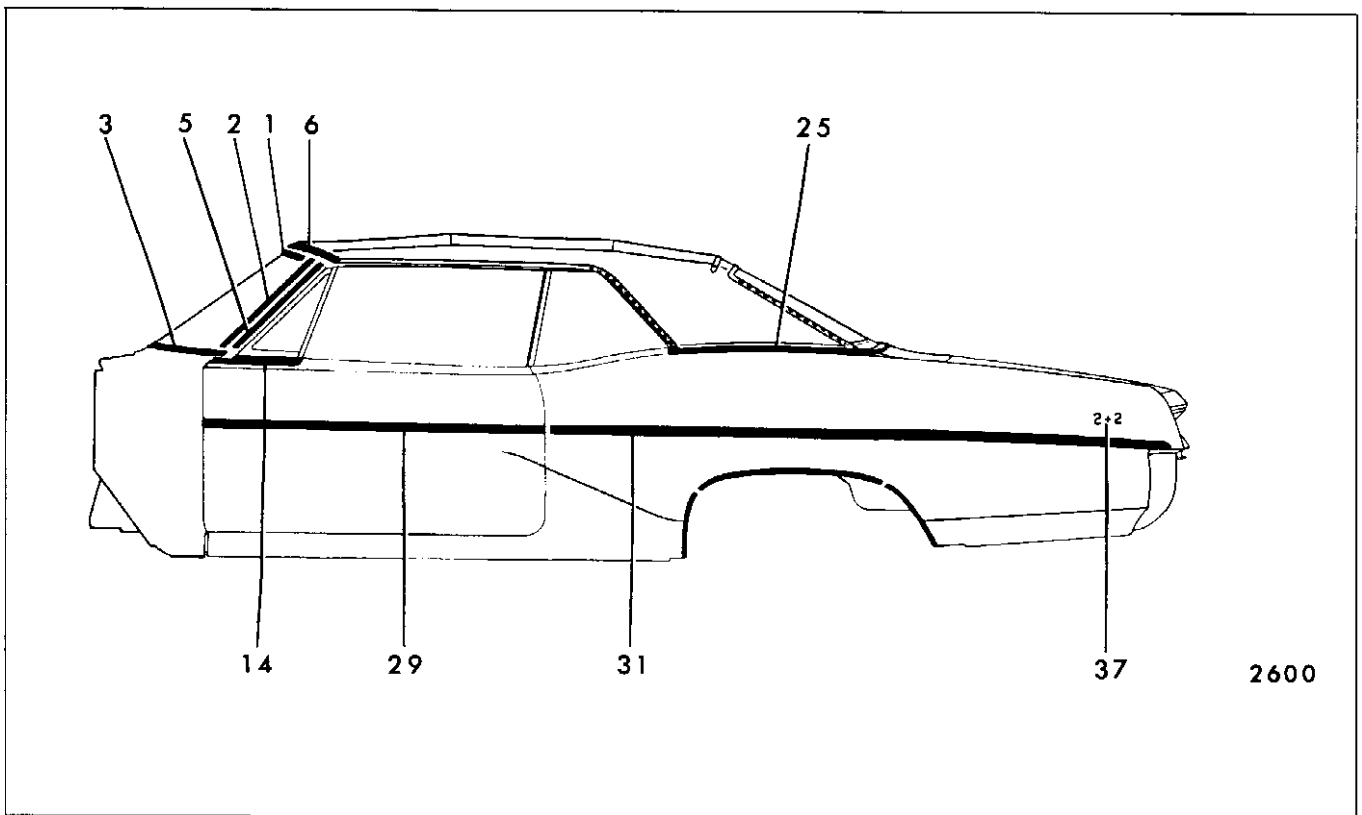

Fig. 17-53—Pontiac 25267 Styles

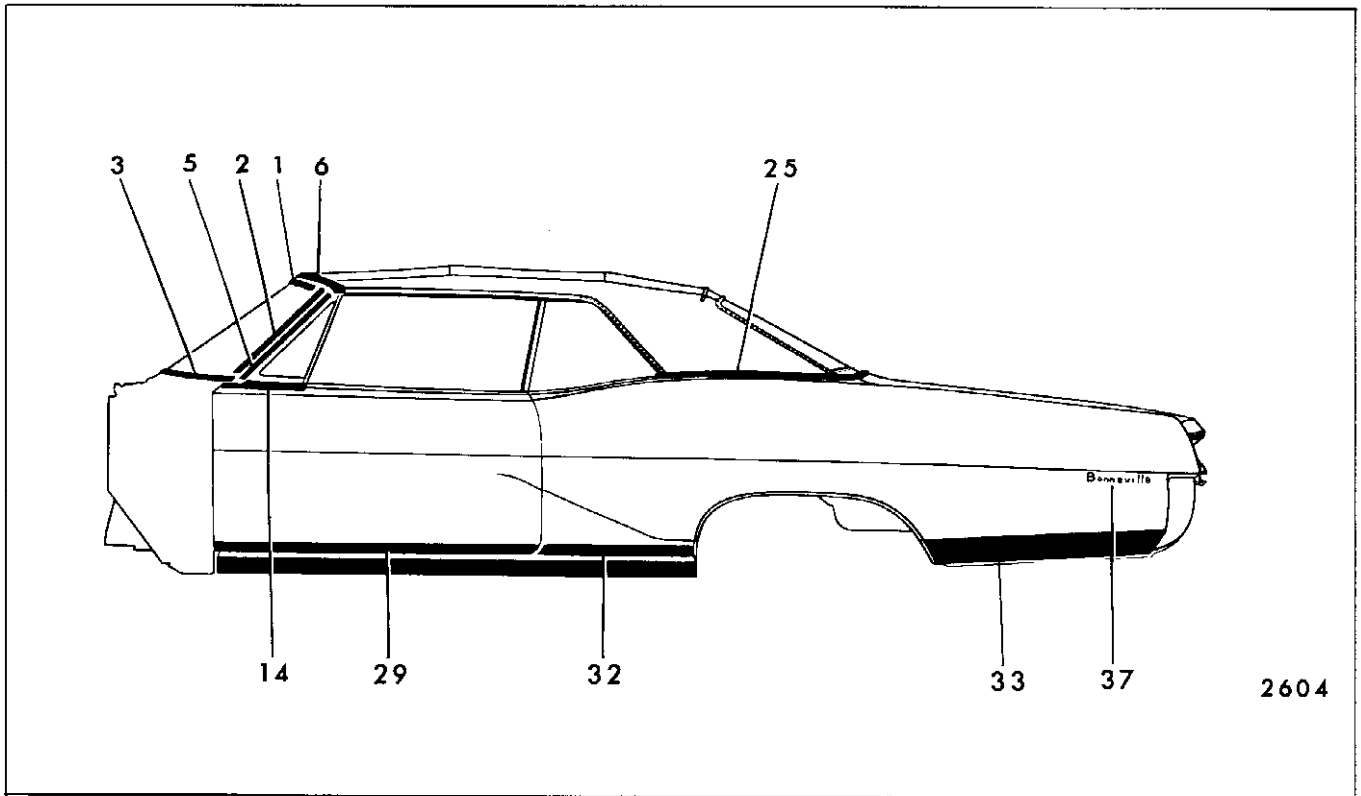

Fig. 17-54—Pontiac 26267 Styles

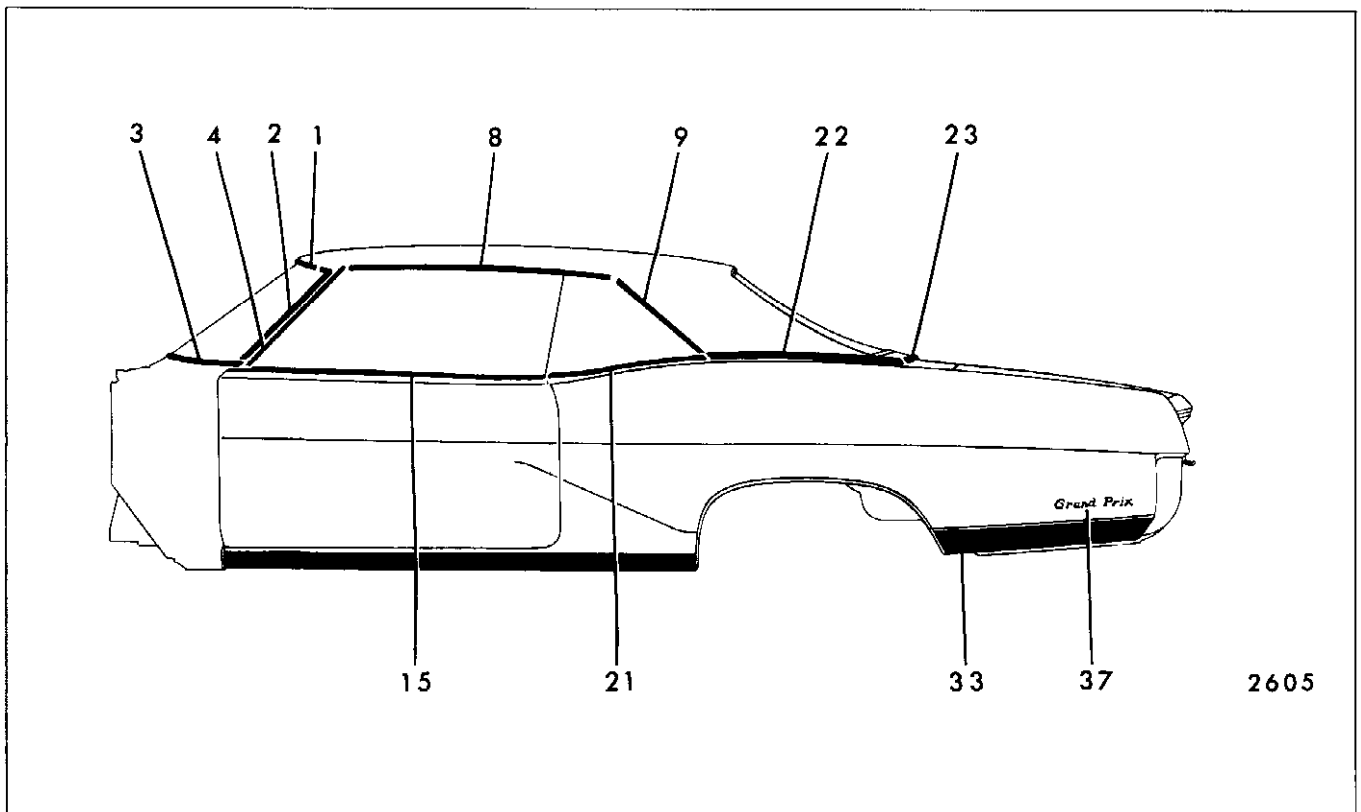

Fig. 17-55—Pontiac 26657 Styles

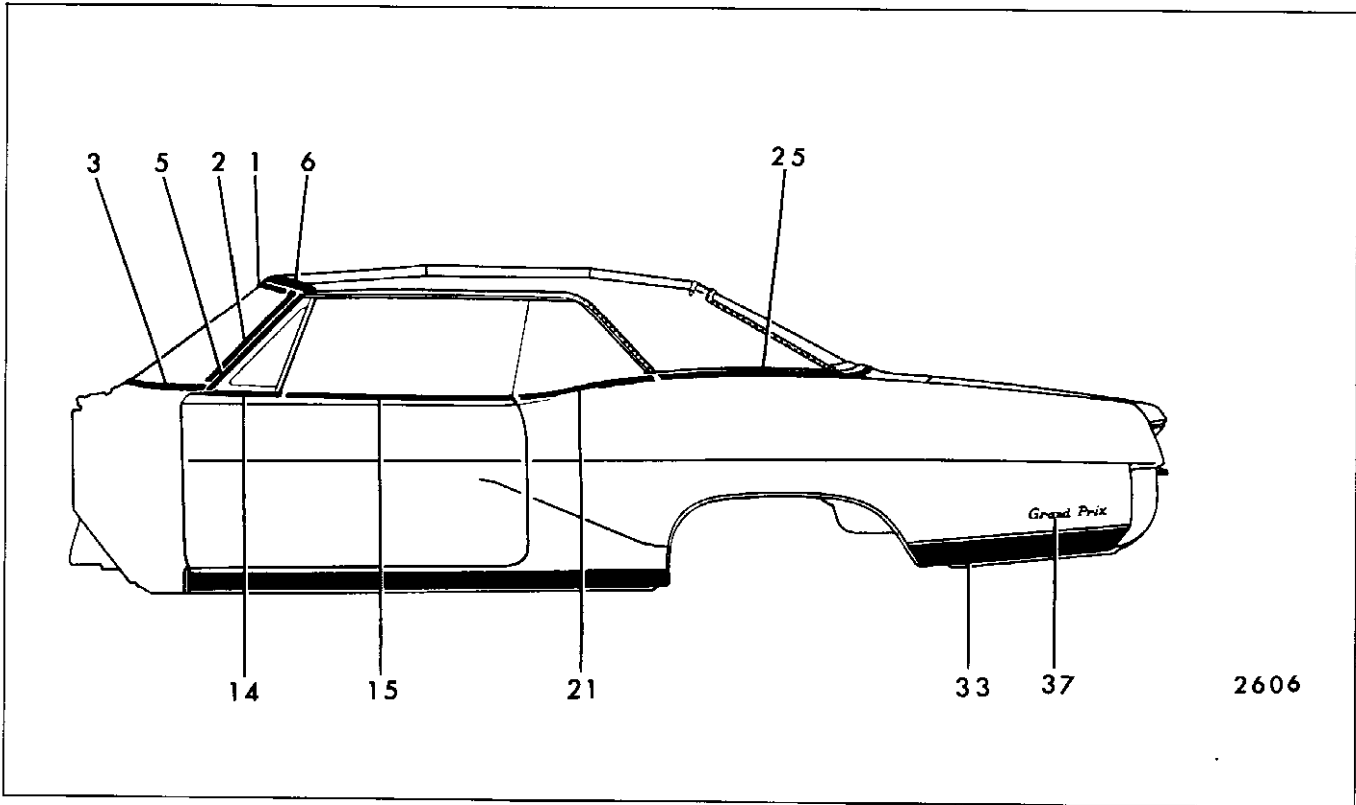

Fig. 17-56—Pontiac 26667 Styles

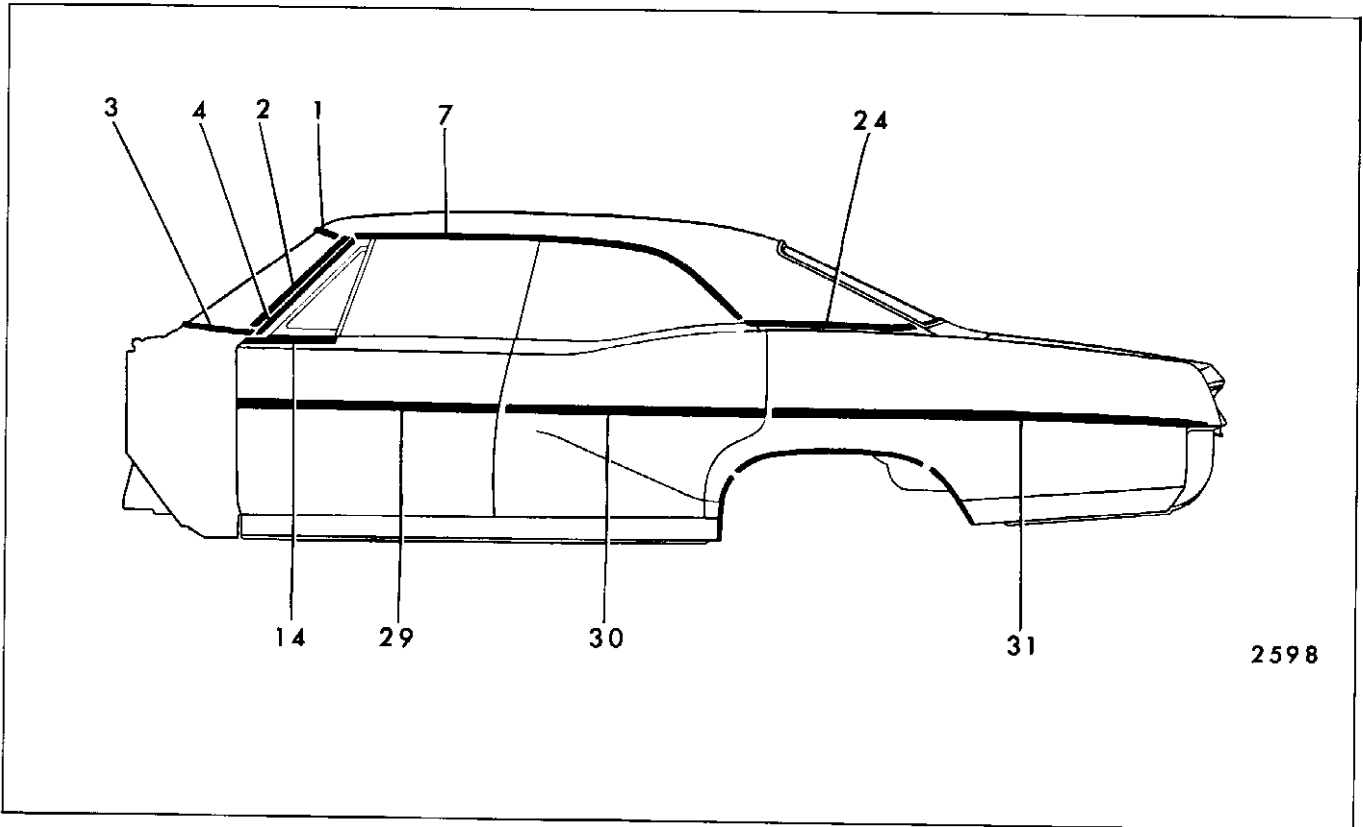

Fig. 17-57—Pontiac 25239-25639 Styles

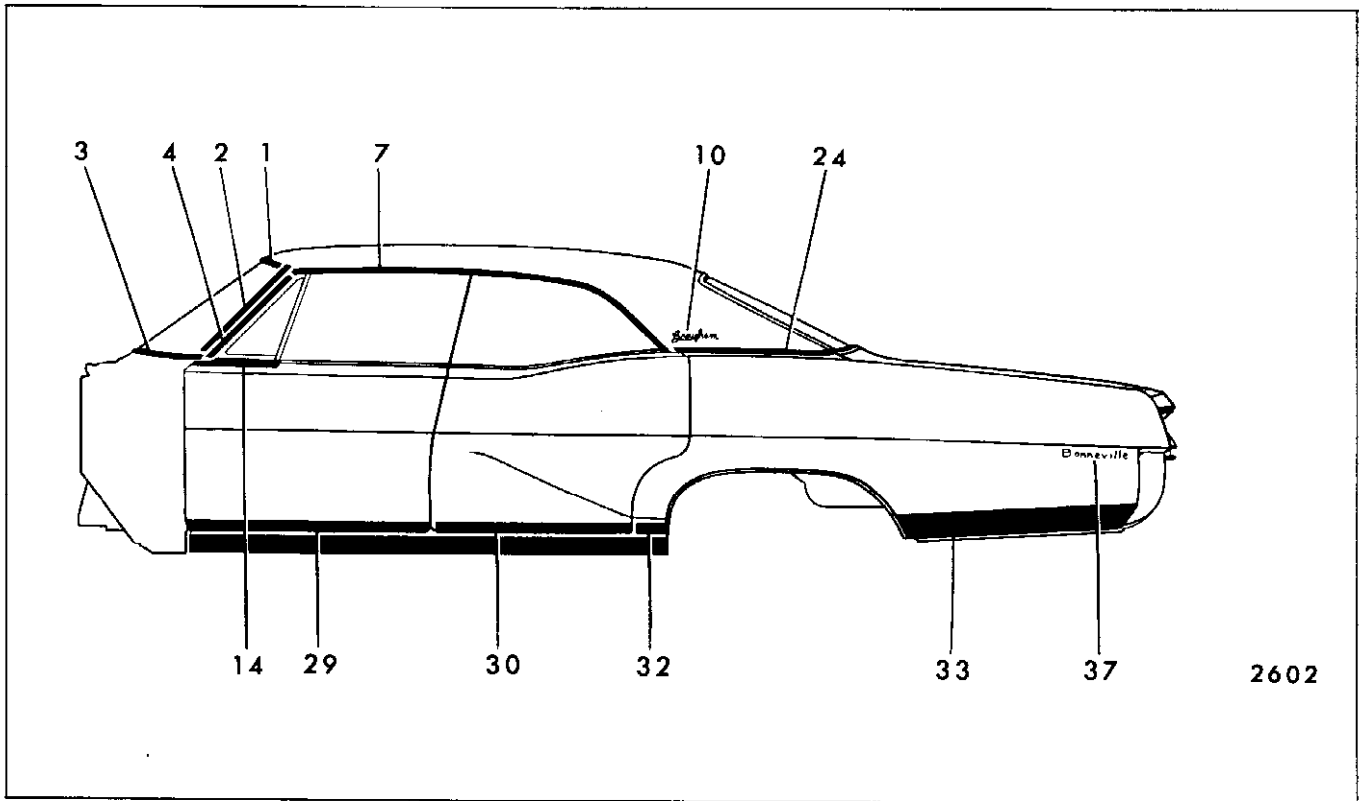

Fig. 17-58—Pontiac 26239 Styles

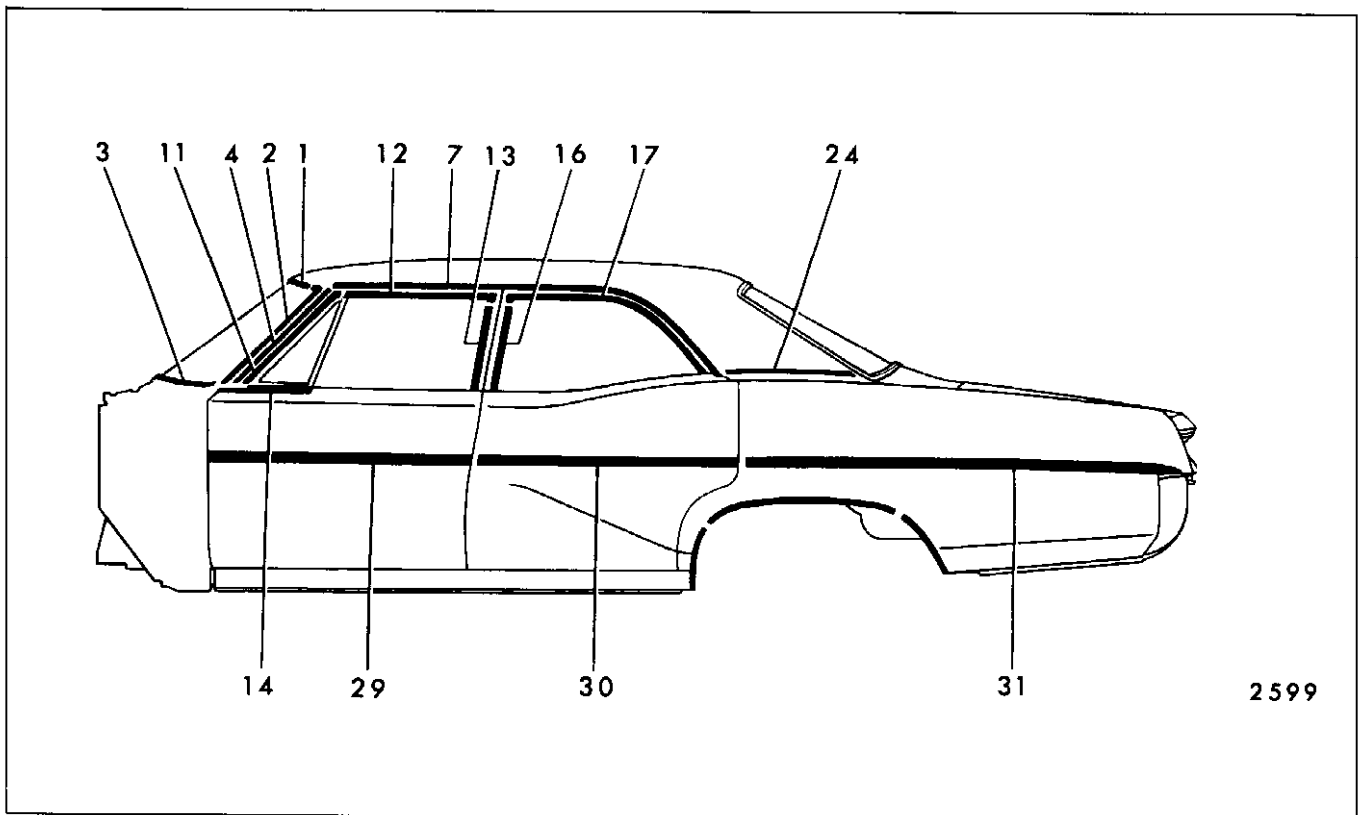

Fig. 17-59—Pontiac "B-69" Styles

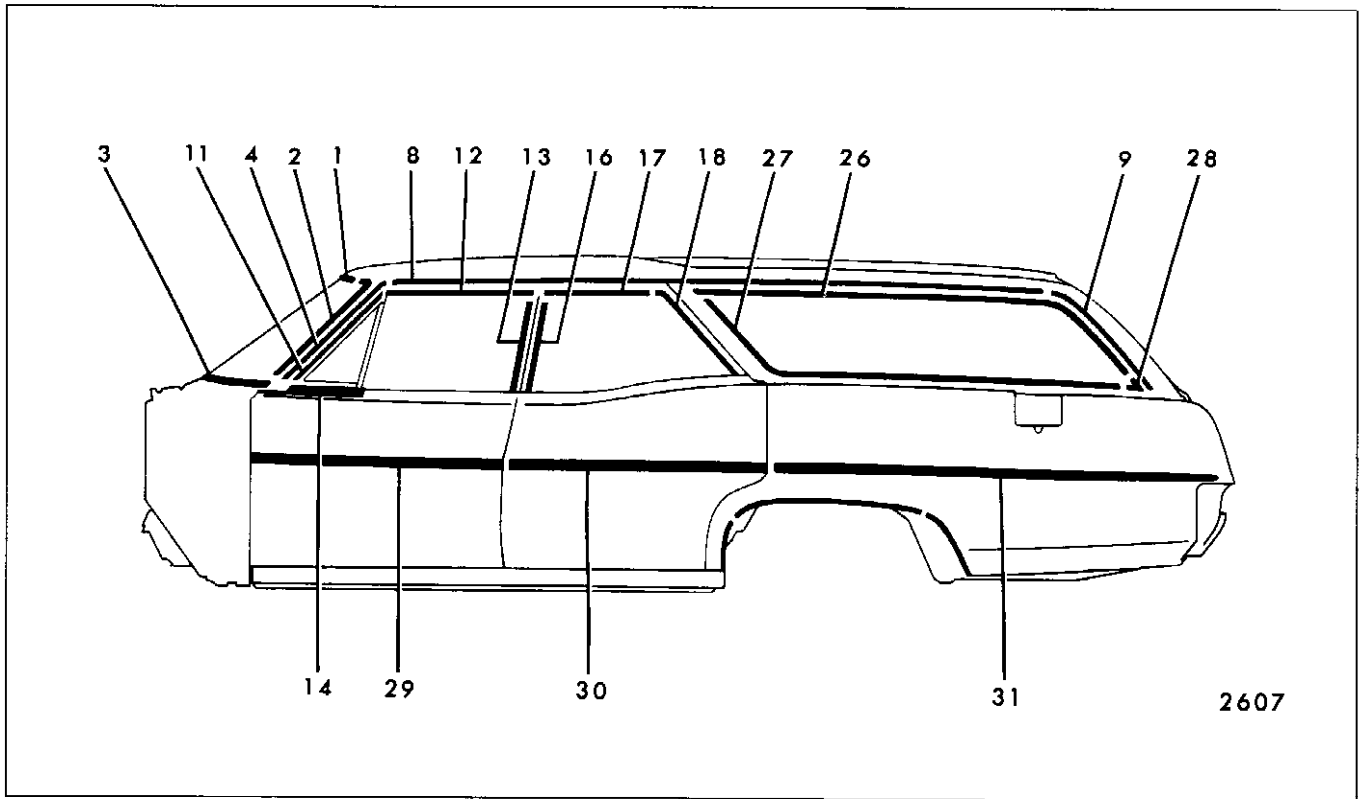

Fig. 17-60—Pontiac 25235-45 Styles

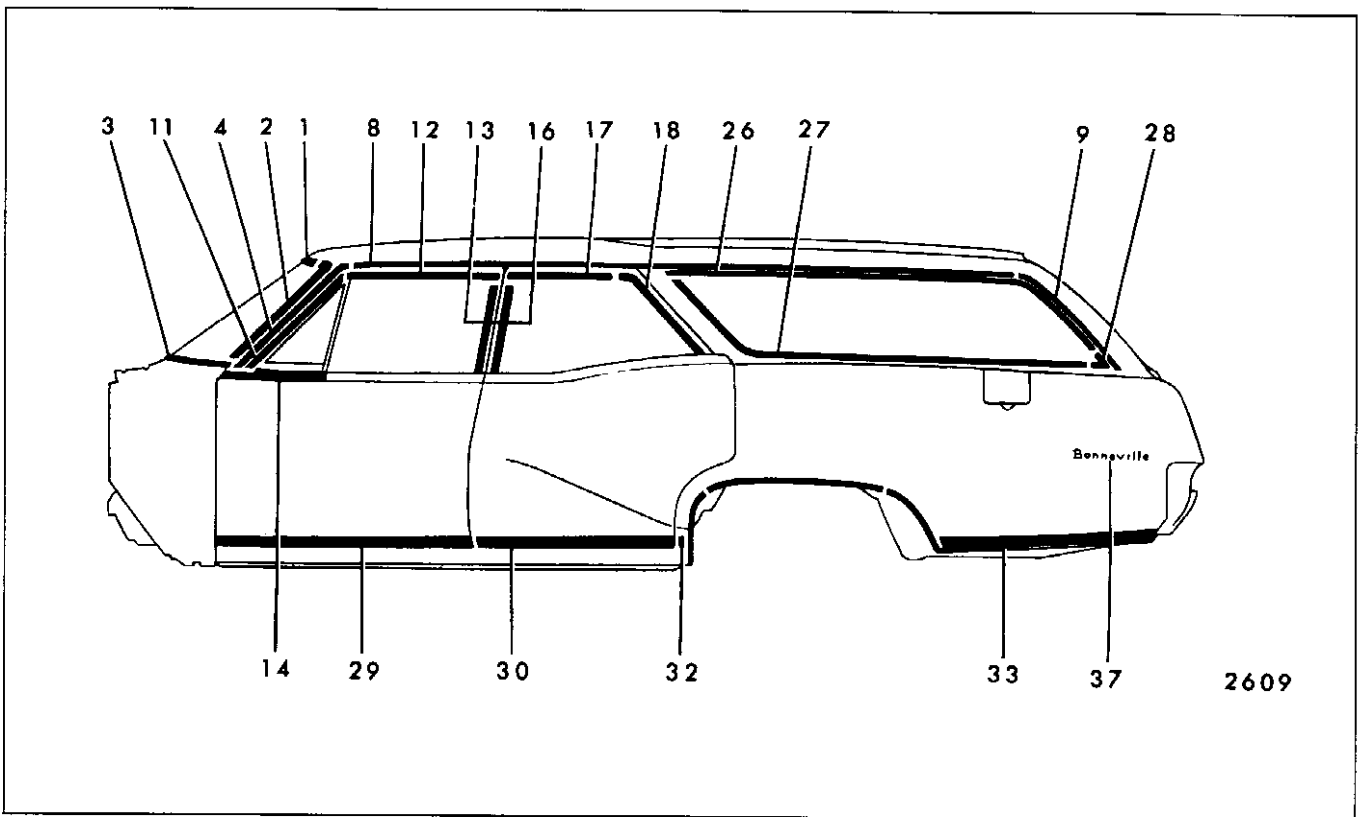

Fig. 17-61—Pontiac 26245 Styles

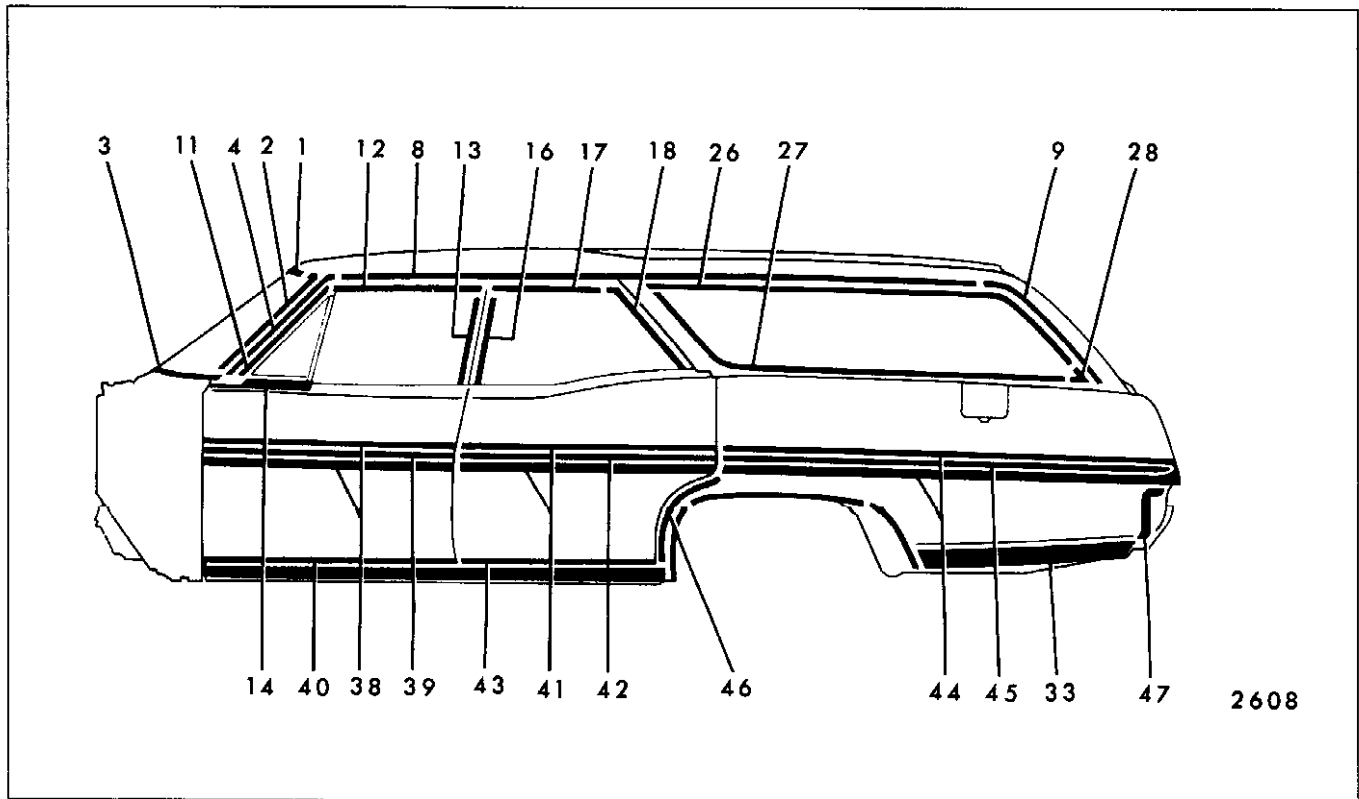

Fig. 17-62—Pontiac 25635-45 Styles

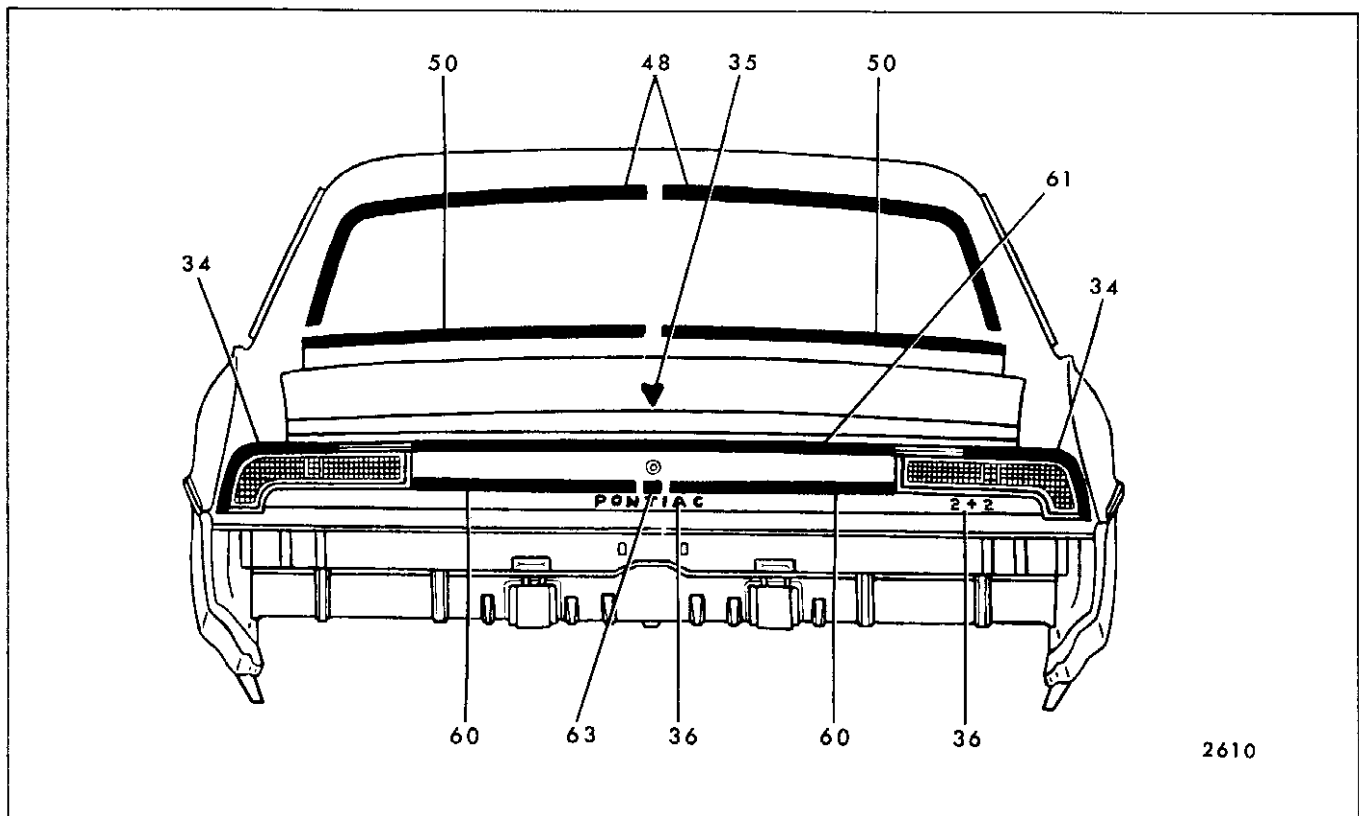

Fig. 17-63—Pontiac 25200-25600 Styles (Except 35-45 Styles)

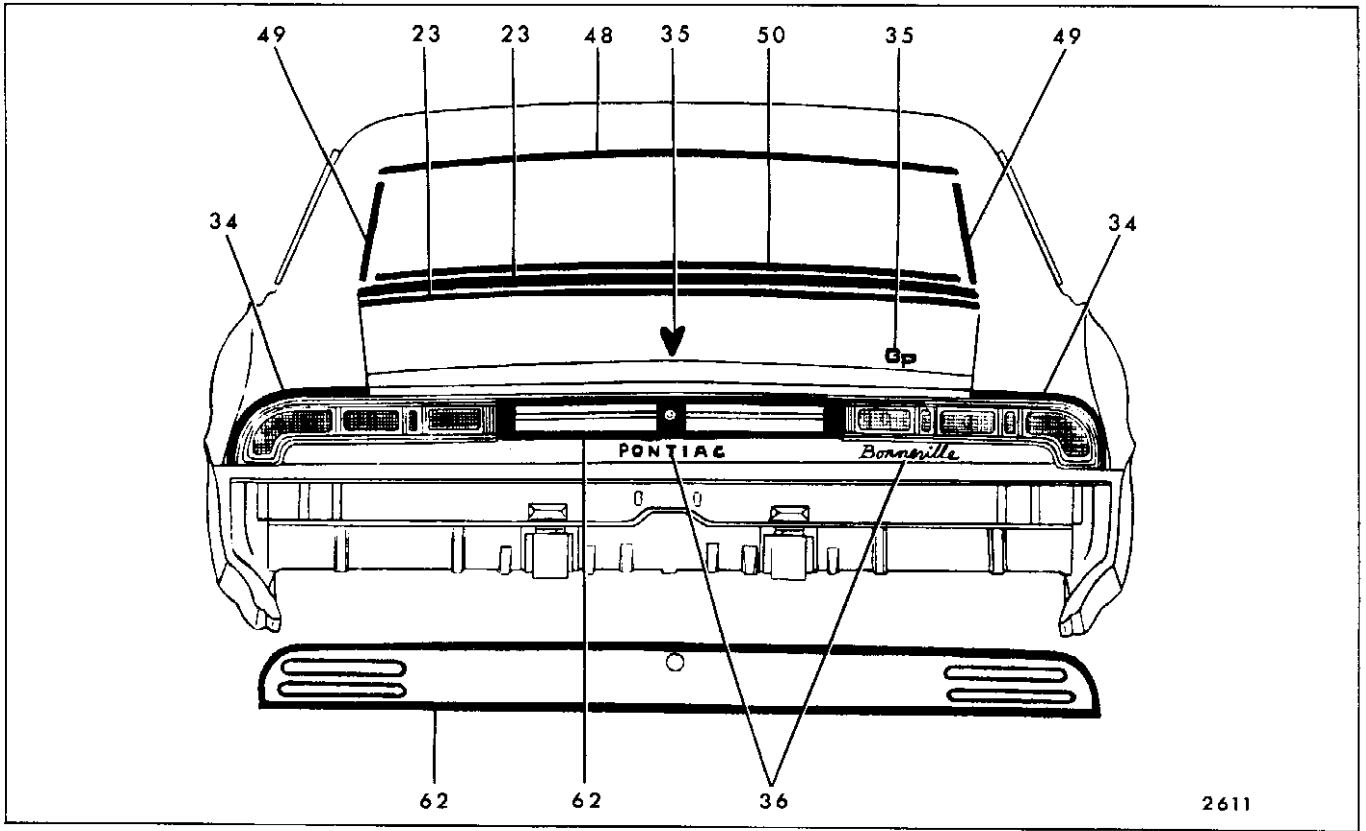

Fig. 17-64—Pontiac 26200-26600 Styles (Except 45 Styles)

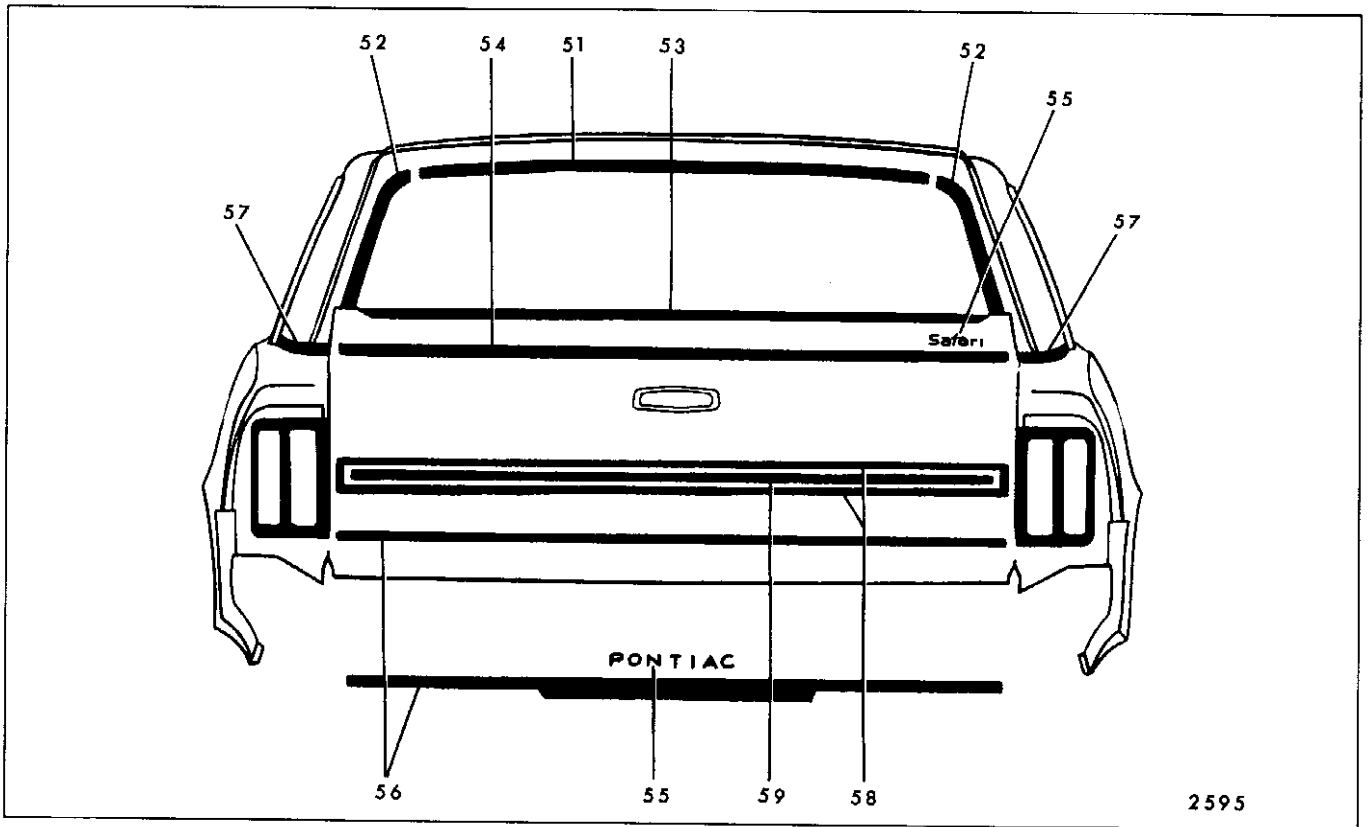

Fig. 17-65—Pontiac 25235-45-25635-45 Styles

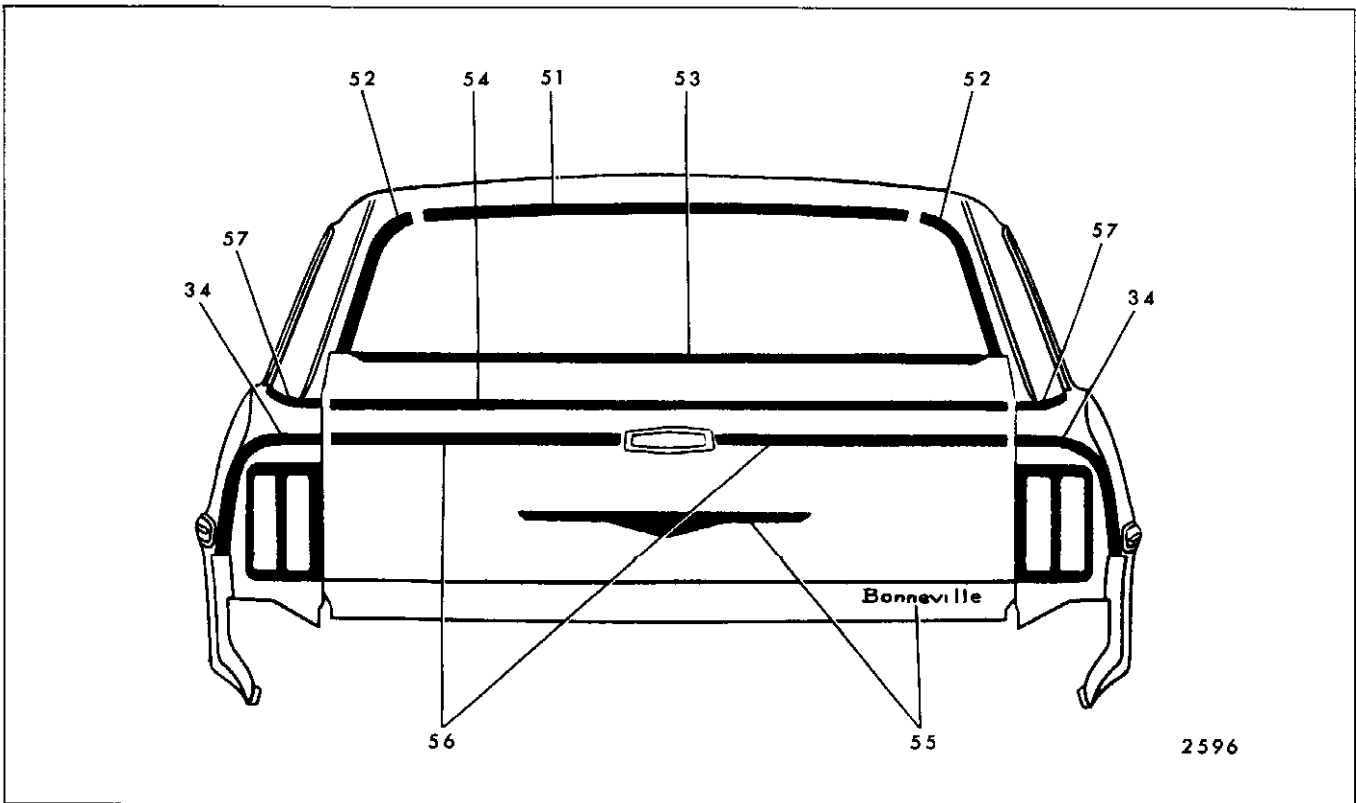

Fig. 17-66—Pontiac 26245 Styles