

METHODS OF MOLDING RETENTION

OLDSMOBILE "B-C" BODIES - 35000 AND 38000 SERIES
 FIGURES 17-76 THROUGH 17-91

Key	Molding Name	Series or Styles	Screws	Spring (Self-Retained)	Snap-On Clips or Retainers On Panel	Snap-On Clips On Molding	Studs With Attaching Nuts	Engages With Other Moldings	Remove Hardware Or Trim
1	Windshield Reveal Upper	All			X			Windshield Reveal Side	
2	Windshield Reveal Side	All			X			Windshield Reveal Lower	
3	Windshield Reveal Lower	All	X						Cowl Air Intake Grille
4	Windshield Pillar Drip	All (Except 67)	X						Windshield Pillar Weatherstrip and Weatherstrip Retainer
5	Windshield Pillar Finishing	67	X					Windshield Reveal Side	Windshield Pillar Weatherstrip and Weatherstrip Retainer
6	Windshield Header	67	X					Windshield Pillar Finishing Windshield Reveal Upper	Sunshade Support Rear View Mirror Support
7	Roof Drip Molding Scalp	All (Except 67 and 38439-38457)		X				Windshield Pillar Drip	
8	Roof Drip Molding Front Scalp	38439-57		X				Windshield Pillar Drip	
9	Roof Drip Molding Rear Scalp	38439-57	X	X				Roof Drip Molding Front Scalp	Side Roof Rail Weatherstrip Retainer
10	Roof Panel Emblem	35439,38669					X		Rear Quarter Upper Trim Panel
11	Front Door Window Frame Front Scalp	69 (Except 38000 Series)		X					
12	Front Door Window Frame Upper Scalp	69 (Except 38000 Series)		X				Front Door Window Frame Front Scalp	
13	Front Door Window Frame Rear Scalp	69 (Except 38000 Series)		X				Front Door Window Frame Upper Scalp	
14	Front Door Window Belt Reveal (at Vent)	All	X						Front Door Vent. Assembly

METHODS OF MOLDING RETENTION
 OLDSMOBILE "B-C" BODIES - 35000 AND 38000 SERIES
 FIGURES 17-76 THROUGH 17-91

Key	Molding Name	Series or Styles	Screws	Spring (Self-Retained)	Snap-On Clips or Retainers On Panel	Snap-On Clips On Molding	Studs With Attaching Nuts	Engages With Other Moldings	Remove Hardware Or Trim
15	Front Door Window Belt Reveal	All	X					Front Door Window Belt Reveal at Vent	Rubber Bumper on Front Door Window Lower Stop
16	Center Pillar Scalp	38469-38669	X						Side Roof Rail Weather-strip Front and Rear
17	Rear Door Window Frame Front Scalp	69 (Except 38000 Series)		X				Rear Door Window Frame Upper Scalp	
18	Rear Door Window Frame Upper Scalp	69 (Except 38000 Series)		X					
19	Rear Door Window Belt Reveal	39,69	X						Rubber Bumper on Rear Door Window Lower Stop
20	Rear Quarter Window Belt Reveal	57,67,87	X						Rear Quarter Window Lower Stop
21	Rear Quarter Window Belt Reveal Escutcheon	87		X				Rear Quarter Window Belt Reveal	
22	Rear Quarter Belt Reveal	All			X	X	X		Rear Quarter Upper Trim Panel
23	Rear Quarter Belt Reveal Corner Escutcheon	38469 38669					X	Rear Quarter Belt Reveal	
24	Rear End Belt Reveal	38469 38669					X	Rear Quarter Belt Reveal Corner Escutcheon	
25	Rear Quarter Pinch Weld Finishing Molding	67	X		X				
26	Front Door Outer Panel	35439-87					X		Front Door Trim Pad
		35639-67 -69-87	X		X				
		38000	X				X		Front Door Trim Pad

METHODS OF MOLDING RETENTION
 OLDSMOBILE "B-C" BODIES - 35000 AND 38000 SERIES
 FIGURES 17-76 THROUGH 17-91

Key	Molding Name	Series or Styles	Screws	Spring (Self-Retained)	Snap-On Clips or Retainers On Panel	Snap-On Clips On Molding	Studs With Attaching Nuts	Engages With Other Moldings	Remove Hardware Or Trim
27	Rear Door Outer Panel	35439					X		Rear Door Trim Pad
		35639-69	X		X				
		38000	X				X		Rear Door Trim Pad
28	Front of Rear Wheel Opening	35487					X	Rear Wheel Opening Upper	Rear Quarter Trim Pad
		35667-87					X	Rear Wheel Opening	Rear Quarter Trim Pad
		35439	X		X			Rear Wheel Opening Upper	
		35639-69			X		X	Rear Wheel Opening	
29	Rear Wheel Opening Upper	35400			X	X			
29	Rear Wheel Opening	35600	X						
		35800	X				X		
30	Rear of Rear Wheel Opening	All					X	Rear Wheel Opening (35000 Styles Only)	
31	Rear Quarter Outer Panel Name Plate	35800 38000					X		
32	Back Window Reveal Upper	All			X			Back Window Reveal Side	
33	Back Window Reveal Side	All (Except 35069 Styles)			X			Back Window Reveal Lower	
34	Back Window Reveal Lower	All			X				
35	Rear Compartment Lid Outer Panel Emblem and/or Name Plate	All					X		
36	Rear of Rear Quarter	35000	X						Rear Quarter Extension
37	Rear Compartment Lid Outer Panel	35400	X						
		35600							
		35800					X		
38	Rear Compartment Lid Outer Panel Side	38000	X					Rear Compartment Lid Outer Panel Center	
39	Rear Compartment Lid Outer Panel Center	38000					X		

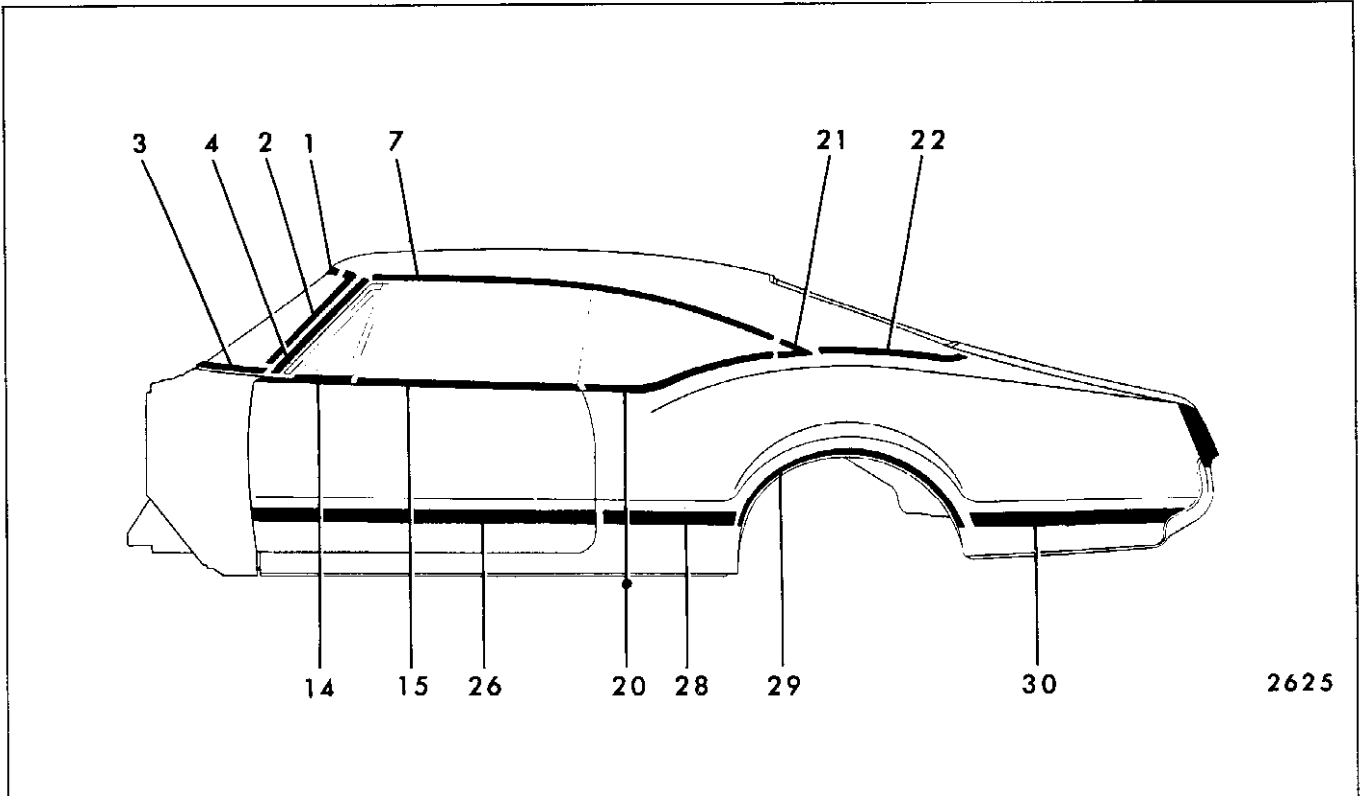

Fig. 17-76—Oldsmobile 35687 Styles

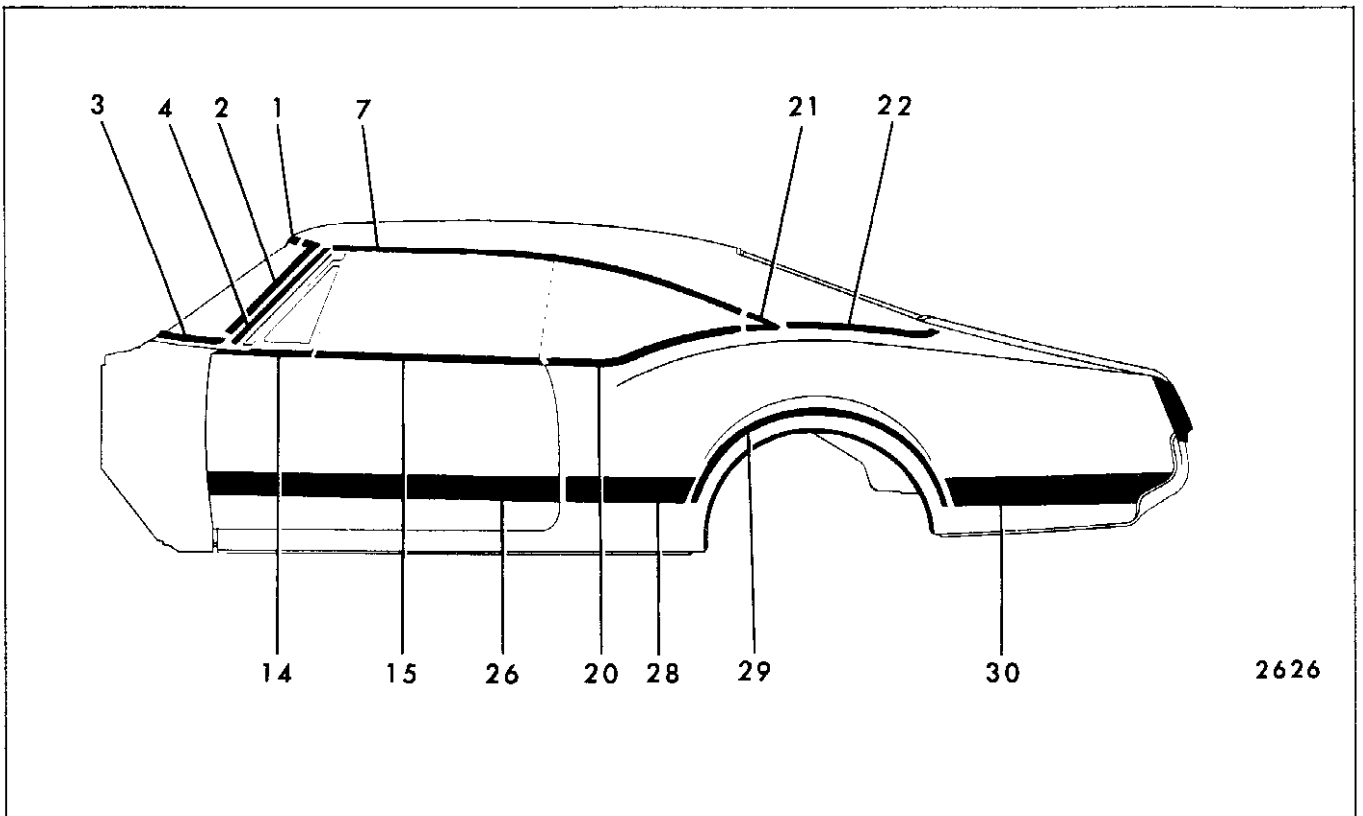

Fig. 17-77—Oldsmobile 35487 Styles

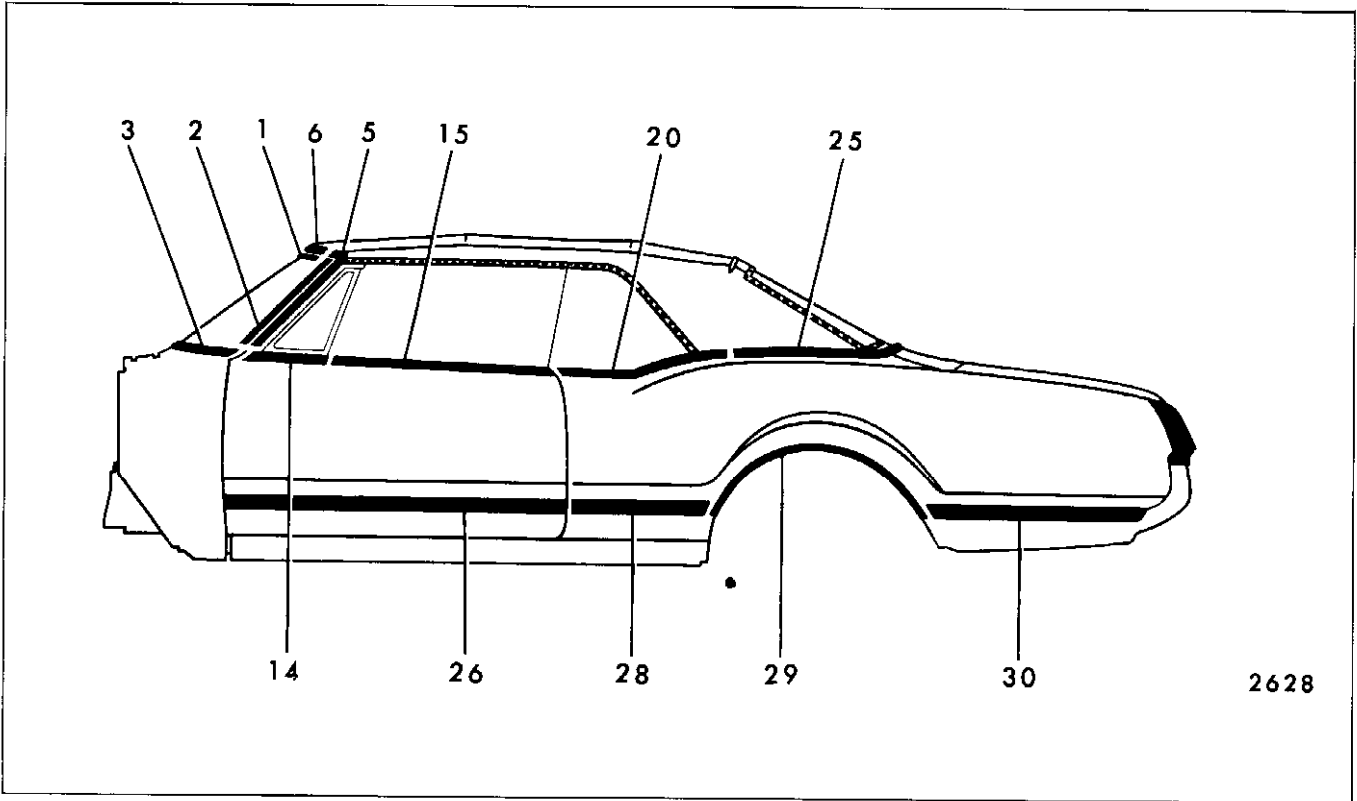

Fig. 17-78—Oldsmobile 35667 Styles

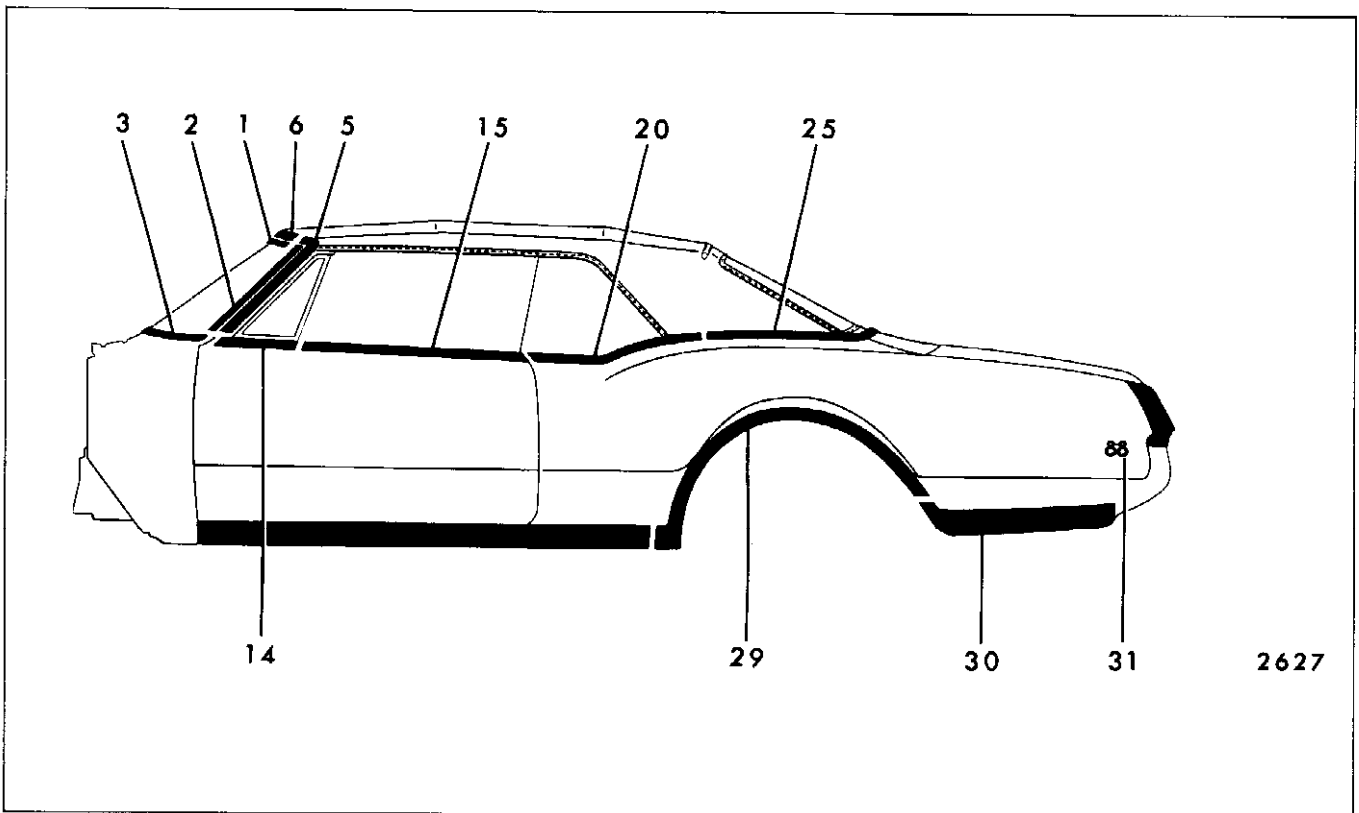

Fig. 17-79—Oldsmobile 35867 Styles

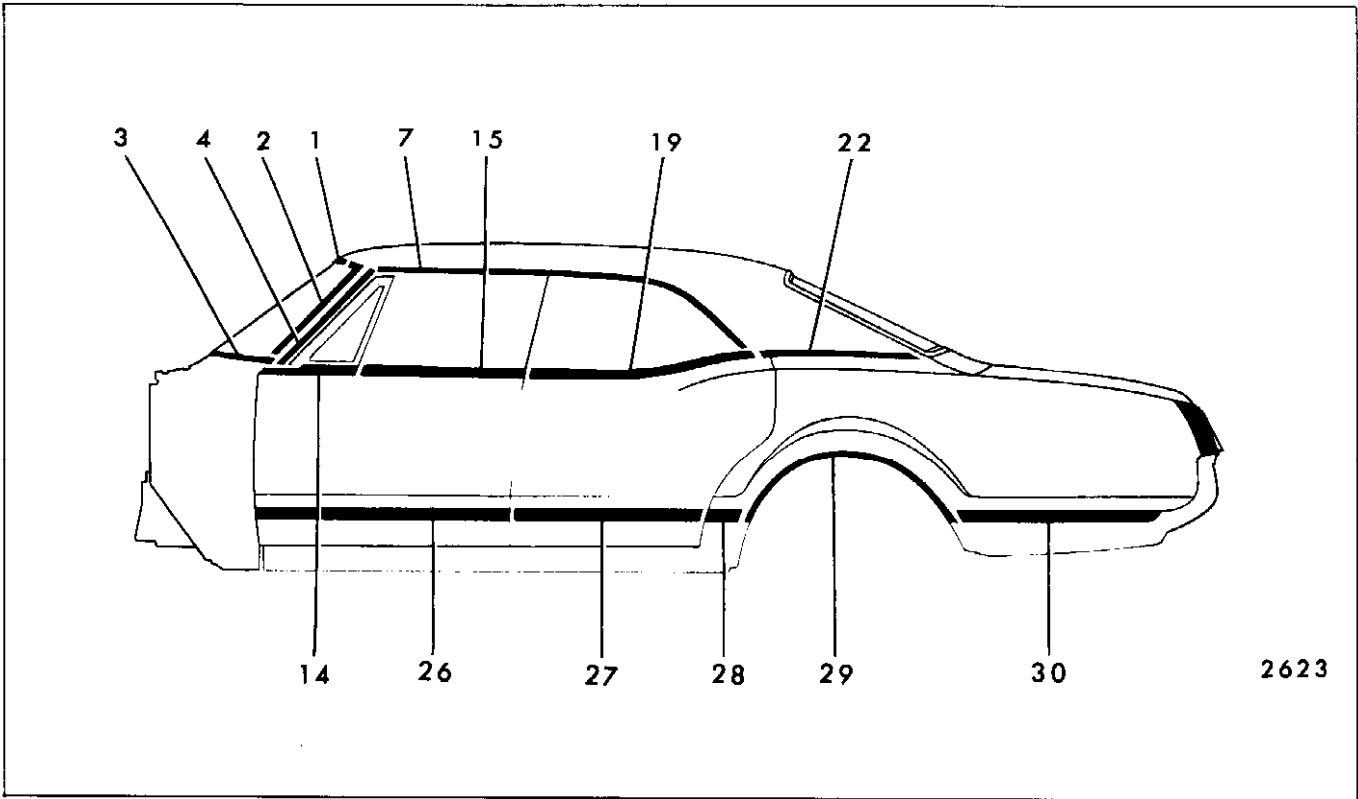

Fig. 17-80—Oldsmobile 35639 Styles

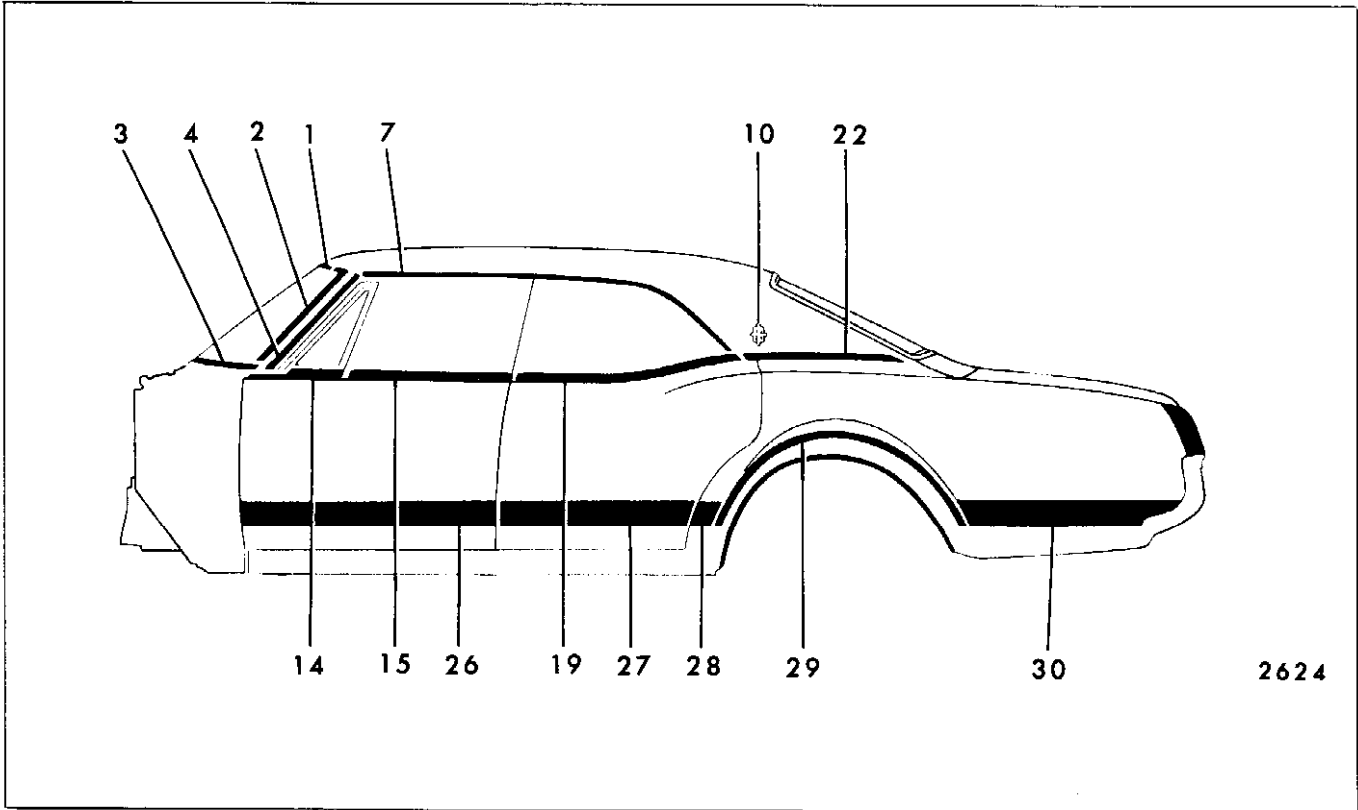

Fig. 17-81—Oldsmobile 35439 Styles

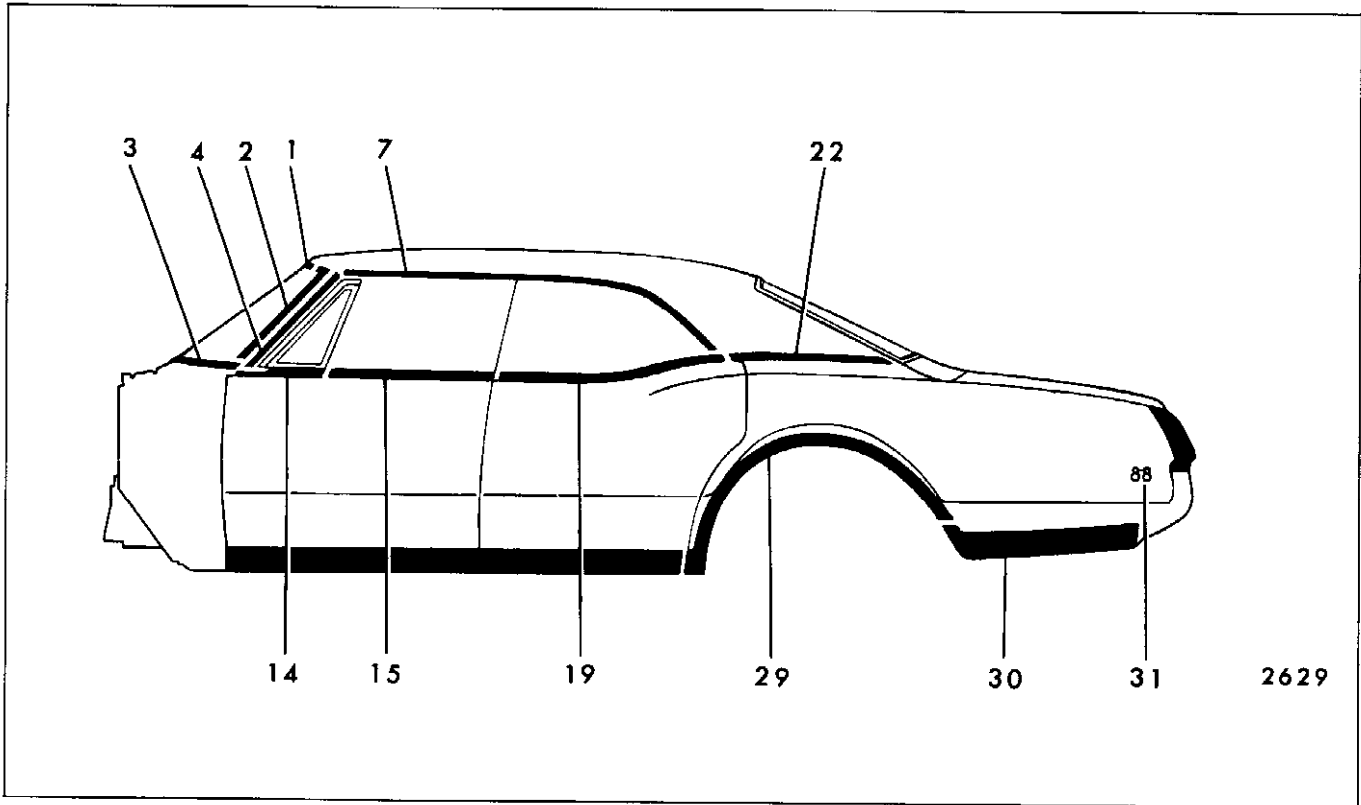

Fig. 17-82—Oldsmobile 35839 Styles

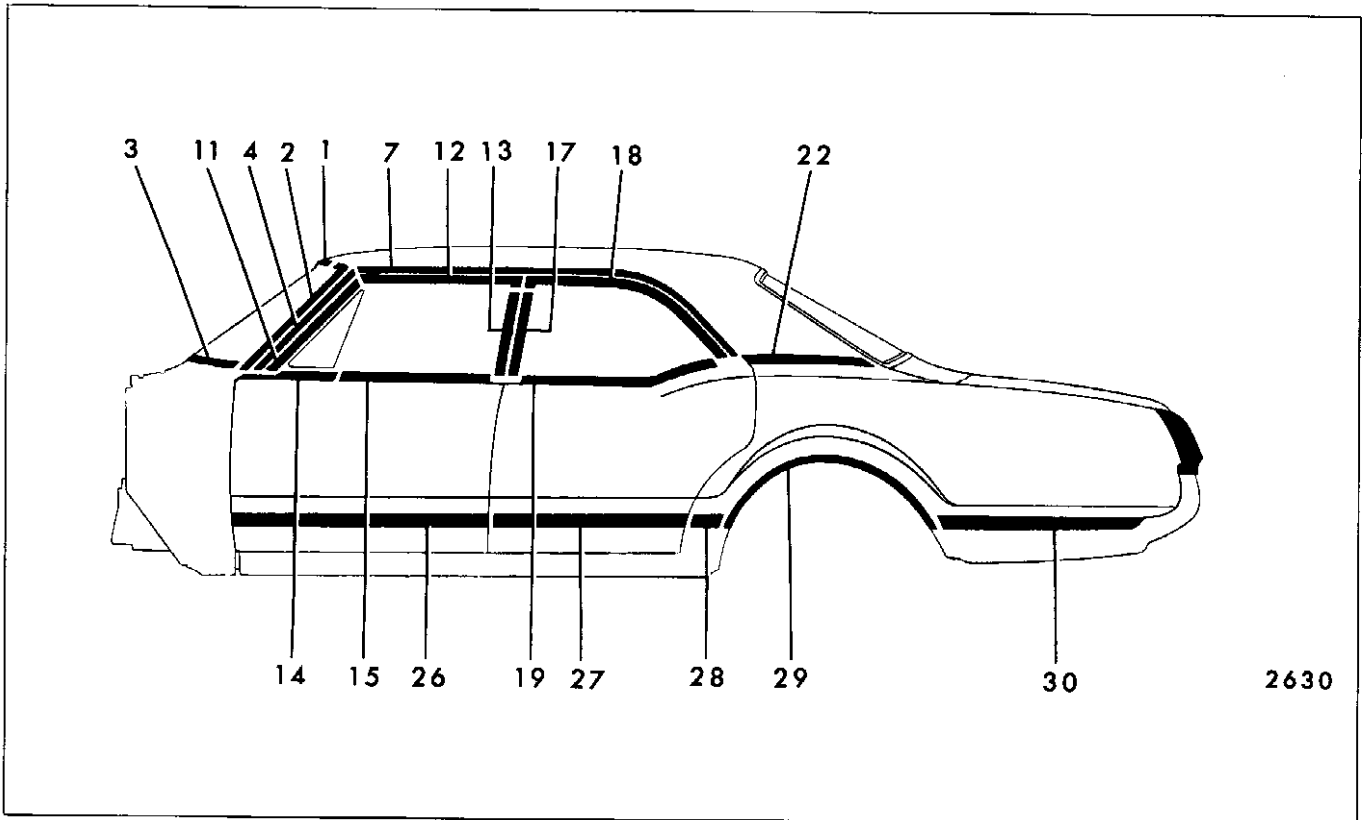

Fig. 17-83—Oldsmobile 35669 Styles

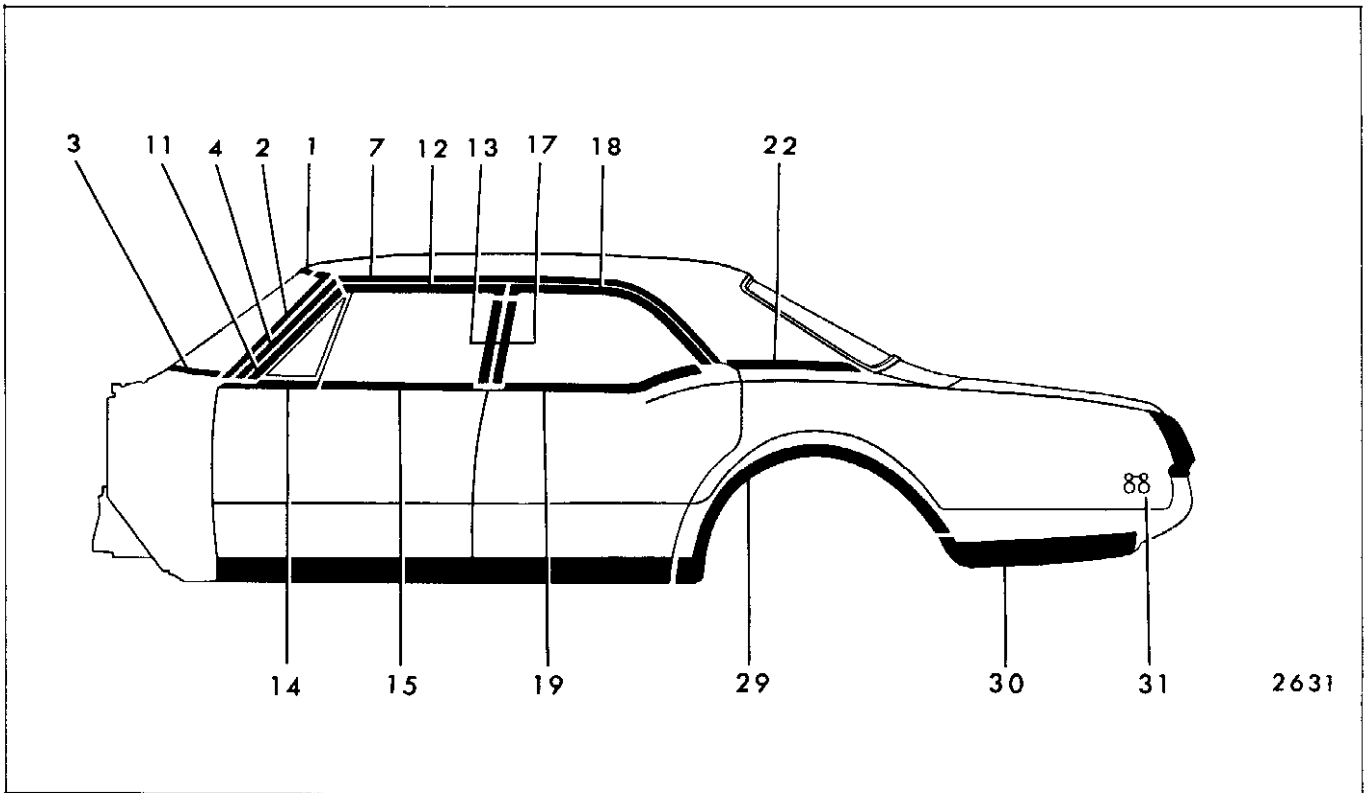

Fig. 17-84—Oldsmobile 35869 Styles

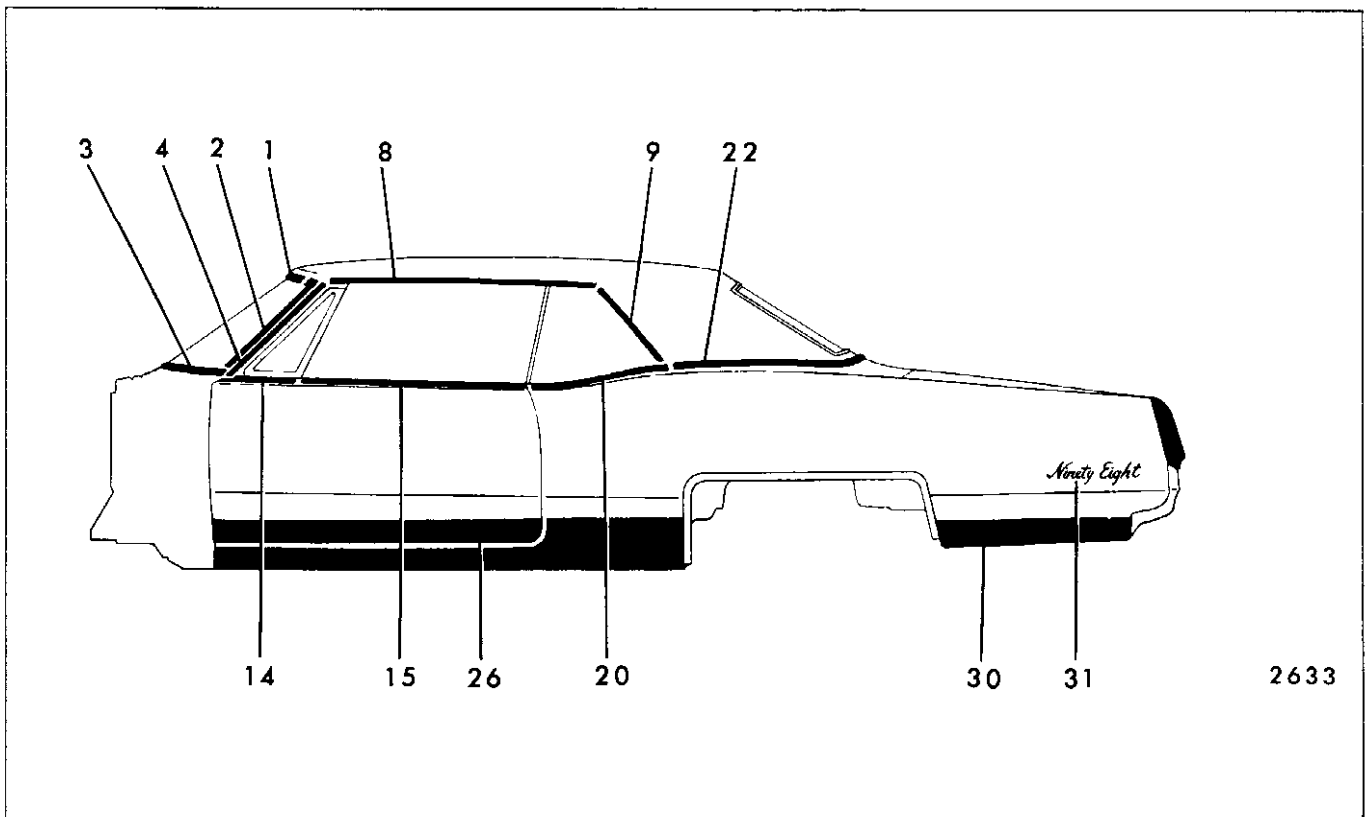

Fig. 17-85—Oldsmobile 38457 Styles

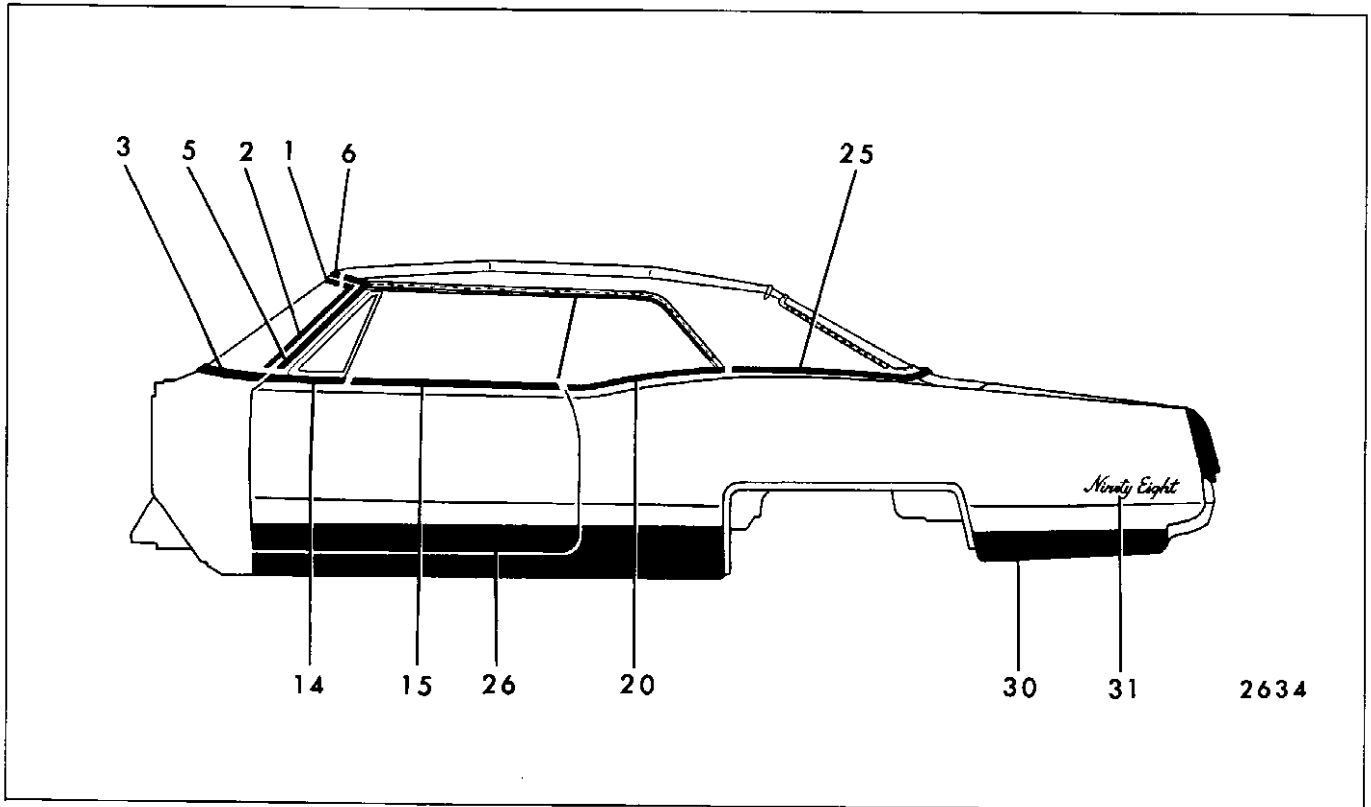

Fig. 17-86—Oldsmobile 38467 Styles

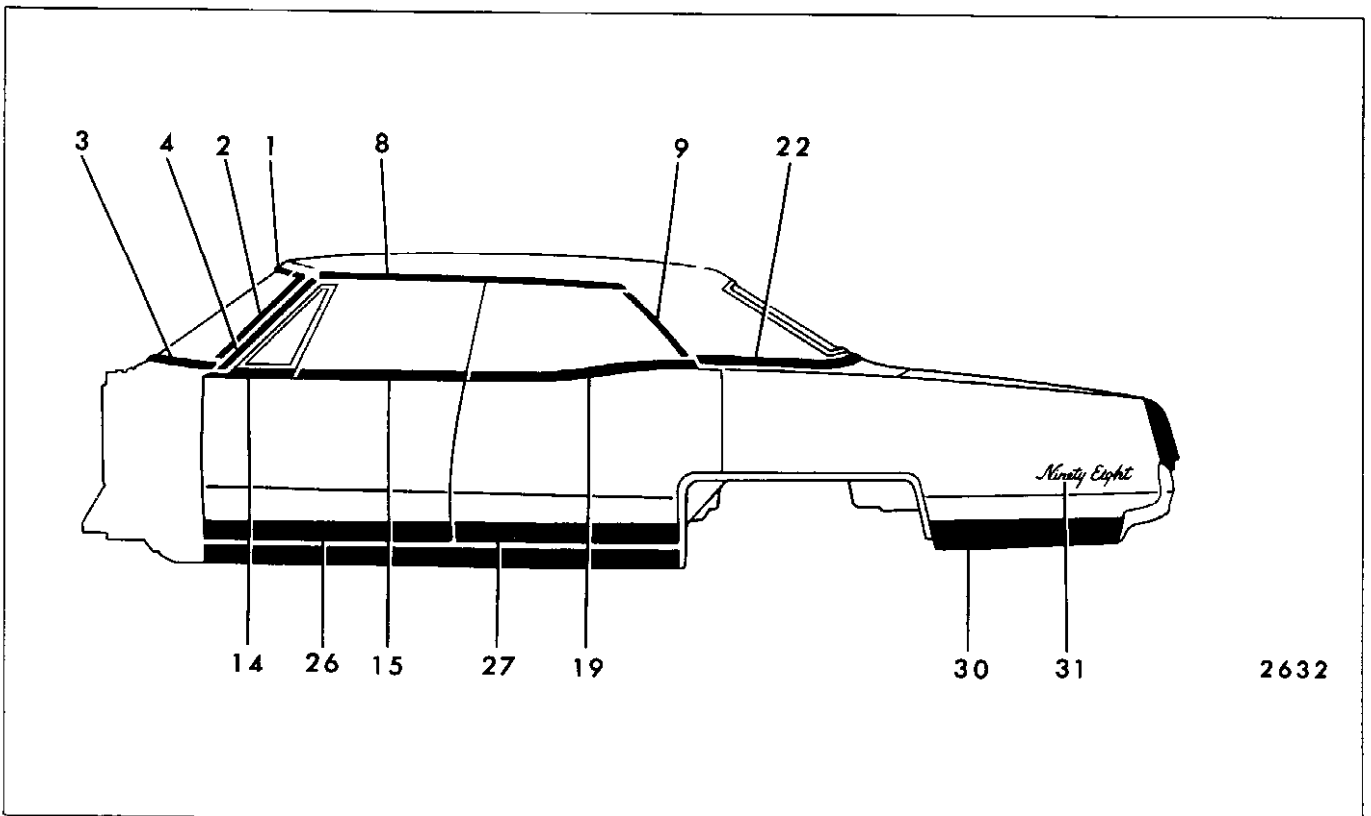

Fig. 17-87—Oldsmobile 38439 Styles

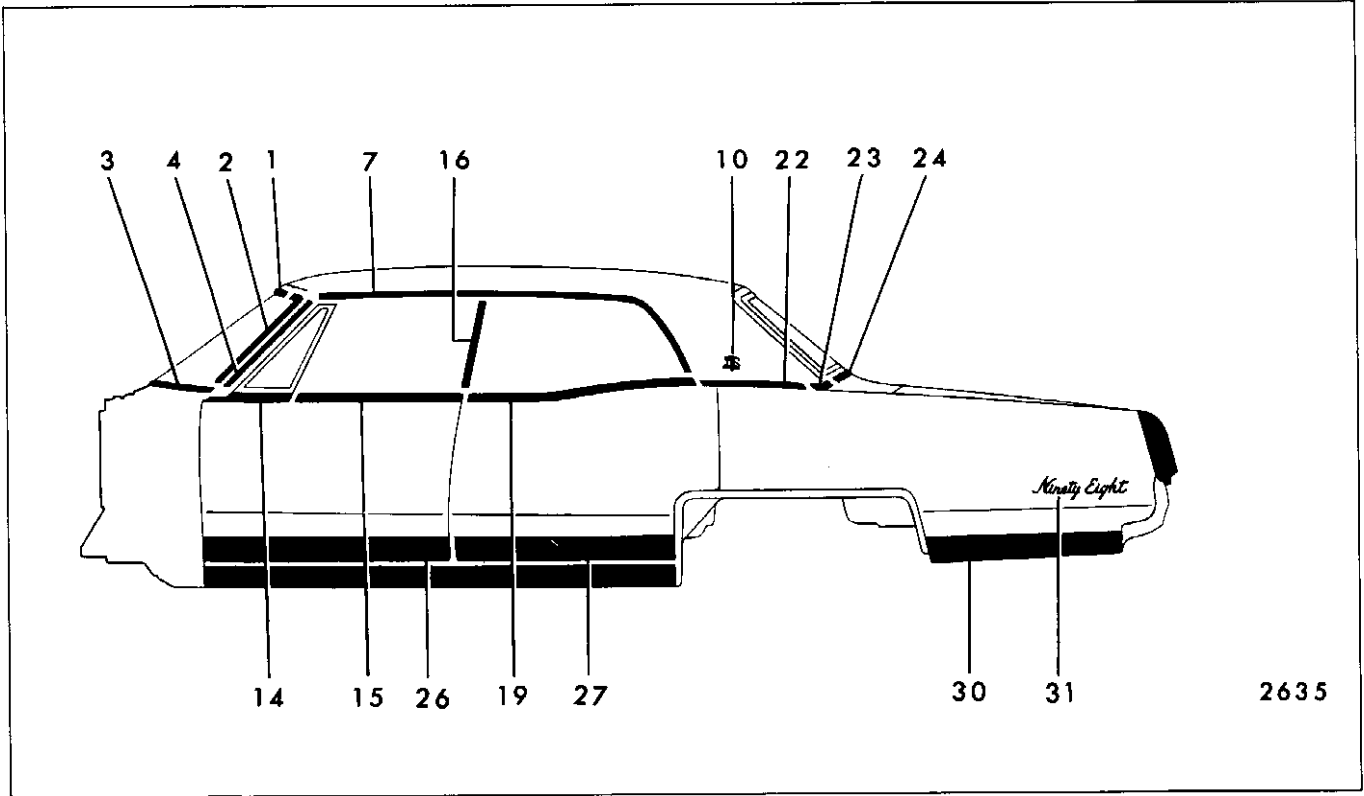

Fig. 17-88—Oldsmobile 38469-38669 Styles

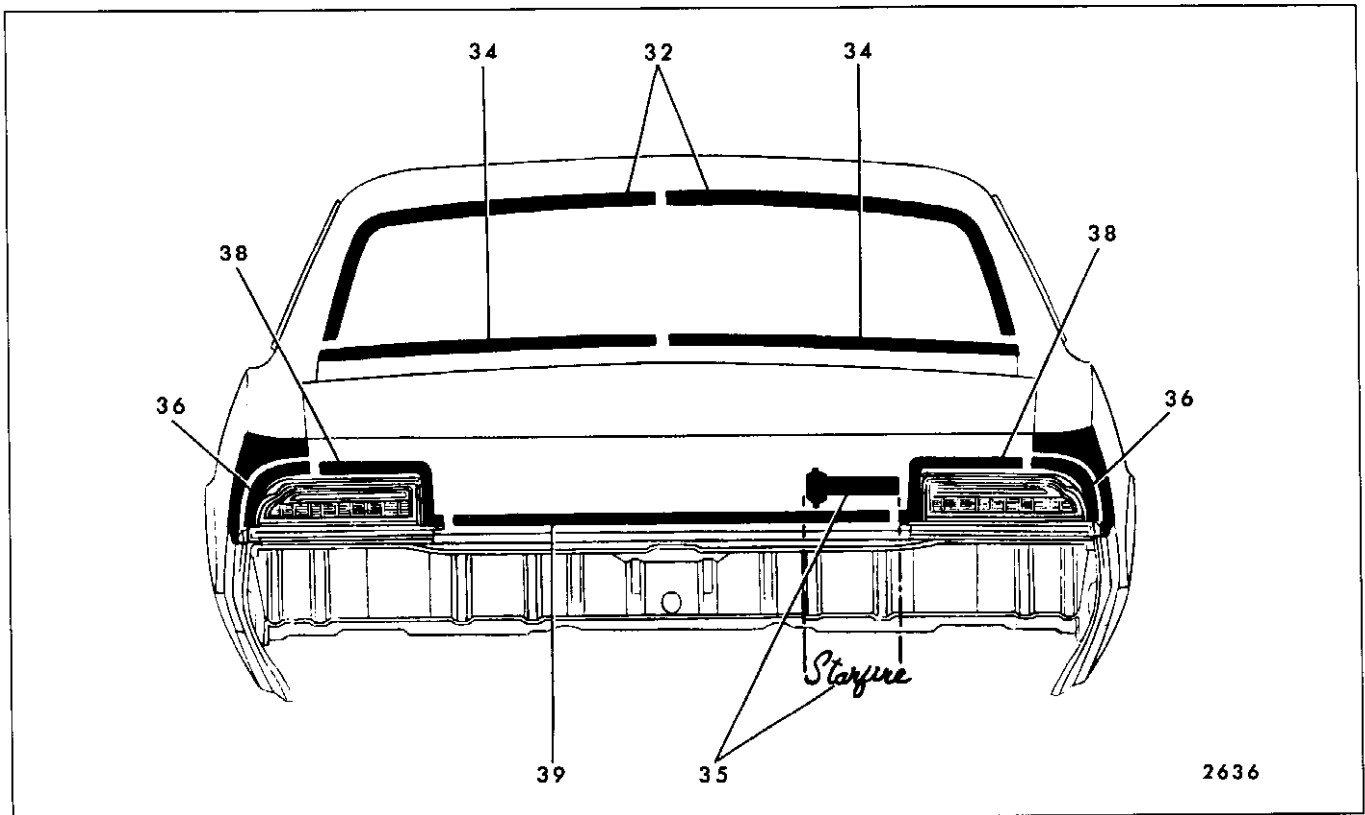

Fig. 17-89—Oldsmobile 35400-35600 Styles

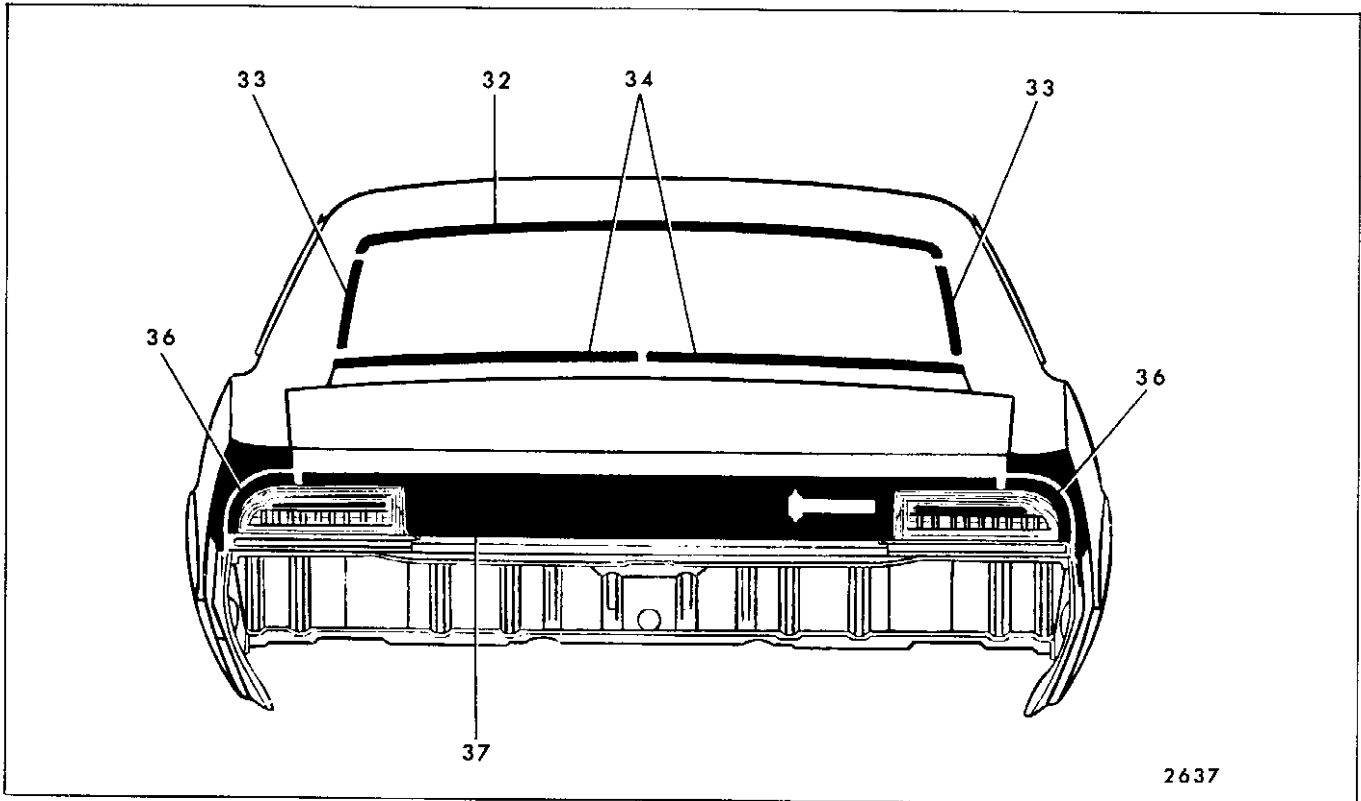

Fig. 17-90—Oldsmobile 35800 Styles

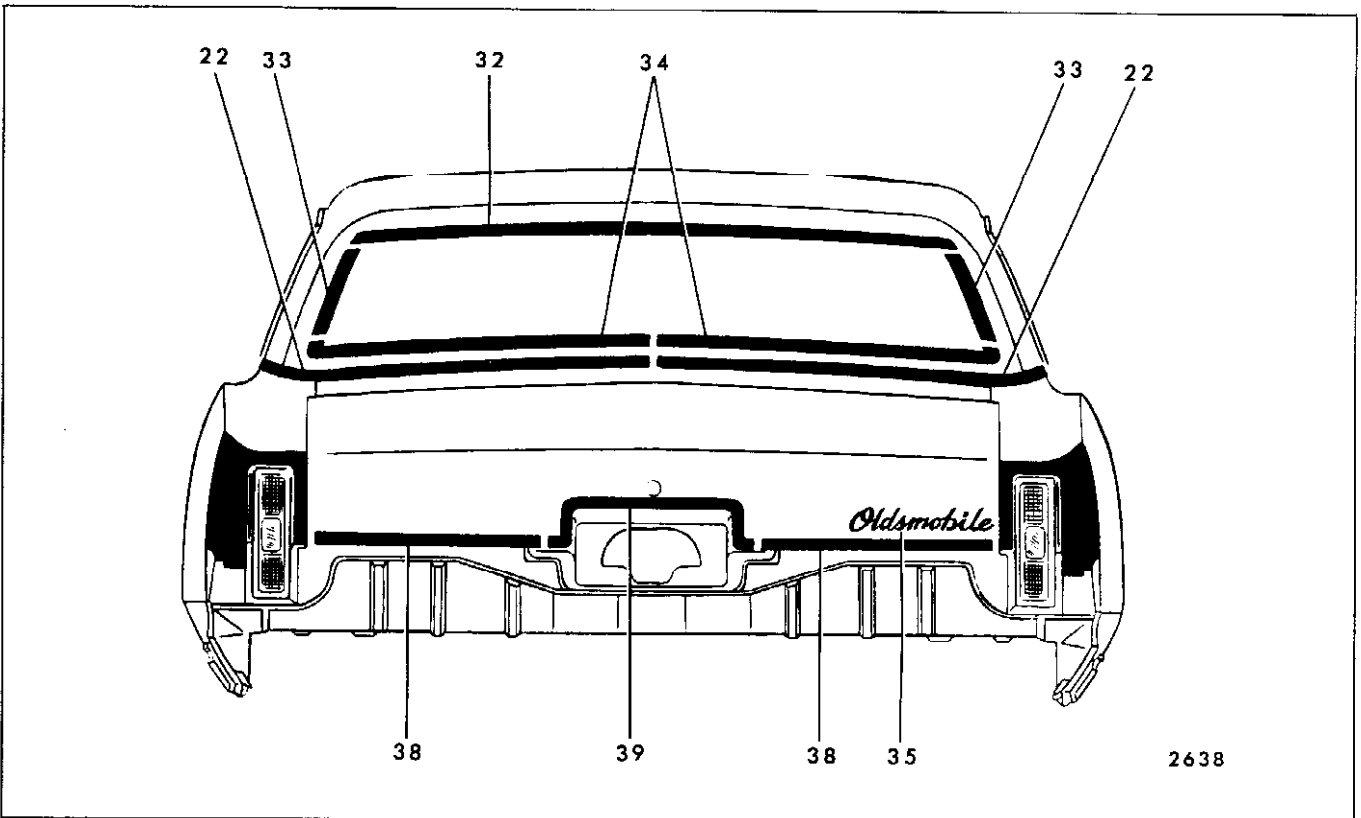

Fig. 17-91—Oldsmobile 38400-38600 Styles